

# MES 6115



15" aluminum casing Manufacturing Execution System  
Panel PC Intel 6th Core i processor



## Features

- True flat PCT or 5-wire resistive type touchscreen supported
- Full system IP66
- NANO coating for easy cleaning and maintenance
- Aluminum casing with ventless and fanless design
- Removable HDD
- Chemical treated and strengthen glass touch panel
- Shock tested using Procedure 1G
- Optional - 2nd display-VGA output
- Optional - 2nd LAN and wireless LAN enable

RoHS CE FC

## Introduction

The SENOR MES 6115 is a robust and integrated Manufacturing Execution System with fanless and ventless design specifically developed to be utilized in harsh environments. Featuring operational effective interface, it aims at enhancing work efficiency and offers safe working environments at the forefront. Its whole aluminum die casting case design without button mechanism aids to increase reliability of the unit without compromising on the functionality. Its compact design is compatible with various mounting solutions and is suitable for various industrial applications such as access control and factory automation.

## Specifications

Model No.	MES 6115PC	MES 6115R
CPU	Intel i3-6100U 2.3 GHz	
System Memory	2* DDR4 SO-DIMM Max. 32GB	
<b>LCD Touch Panel</b>		
LCD Size, Resolution	15" TFT LCD, 1024*768	
Brightness	250 cd/m <sup>2</sup>	
Touch Type	True flat PCT (Projected Capacitive touch)	5-wire Resistive Touch
<b>Connectivity</b>		
Storage devices	1*SATA III for 2.5" 9.5 mm SSD/HDD 1*SATA III for internal Half-Slim SSD 1*SATA III for internal mSATA SSD Support RAID 1 Disk Mirroring	
Giga LAN	1*RJ-45 (10/100/1000 Mbps)	
USB	3*USB2.0, 2*USB3.0	
COM port	3*RJ48 (COM2/COM3/COM4)	
Keyboard	1*PS/2	
Audio	2*Built-in Speakers, 1*Mic+Line out	
<b>Mechanical &amp; Environment</b>		
Dimensions & Weight	389 * 96 * 334 mm(adapter built-in)/ 389 * 67 * 334 mm(external adapter), 8 kgs	
Safety Certifications & IP Rating	FCC/CE, IP 66 Compliance	
Storage & Operating Temp.	-20°C ~ 60°C, 0°C ~ 40°C	
Relative Humidity	10% ~ 90% (non-condensing)	
Power Consumption	60 W maximum	
<b>Software</b>		
Operation System support	Win 7/ Win 7 embedded/ Win 8.1/ Win 8.1 embedded/ Win 10 IoT for Retail 64 bit	
<b>Peripheral Options</b>		
Wireless LAN & Blue Tooth	802.11 b/g/n Wireless LAN or Blue Tooth 4.0	
3G GPRS	WCDMA 850/ 1900/ 2100 MHz EDGE/GPRS/GSM 850/900/1800/1900 MHz	

## Dimensions

Unit: mm

MES 6115PC  
389\*67\*334(mm) - External adapter

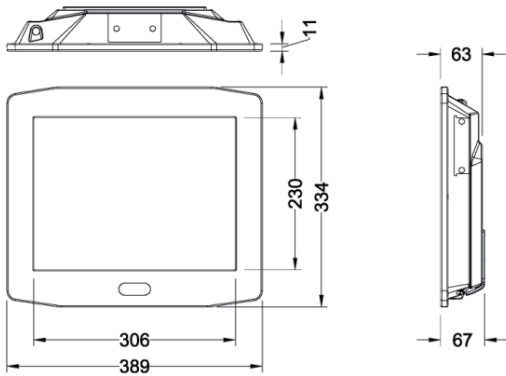

MES 6115PC  
389\*96\*334(mm) - Adapter built-in

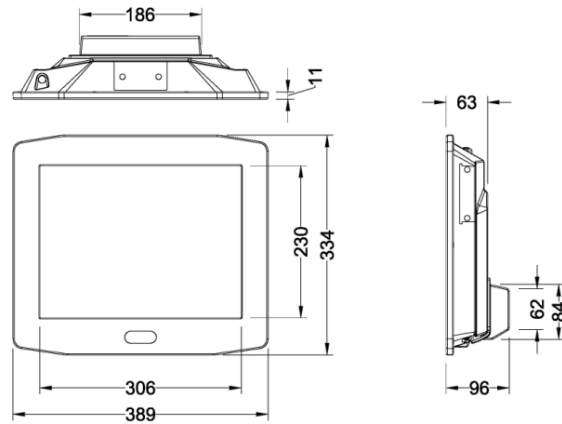

MES 6115R  
389\*67\*334(mm) - External adapter

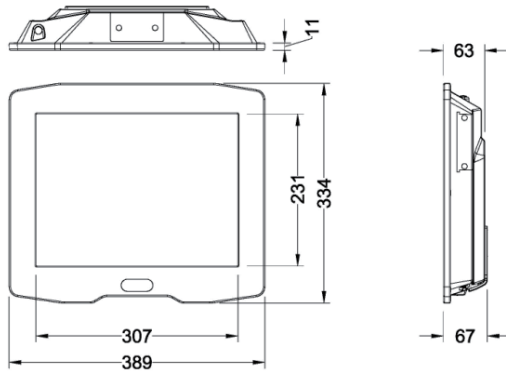

MES 6115R  
389\*96\*334(mm) - Adapter built-in

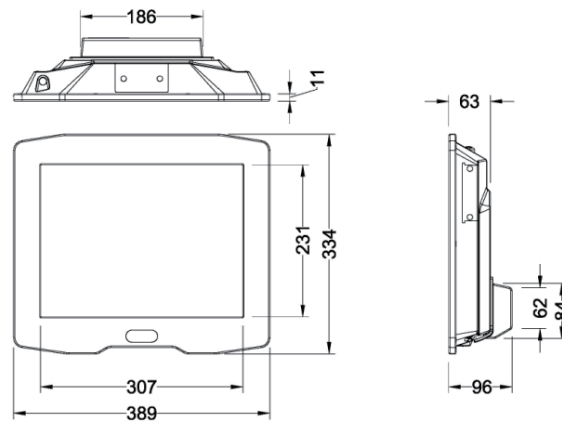

## VESA 75\*75 & 100\*100mm

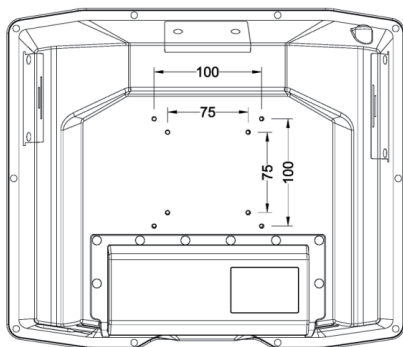

## I/O placement

