



DuraVision® FDX1502T

15" Touch Panel Color LCD Monitor



Highly Durable 15" Monitor with Multiple Mounting Configurations for Industrial Environments

Flexible Installation

To meet the requirements of different industrial installations, the monitor is available in multiple configurations - with a stand, VESA mount, or panel mount.

Durable and Reliable

The monitor can withstand temperatures ranging from 0 - 50°C for high durability in industrial environments. In addition, the cabinet does not contain any ventilation holes, making it impervious to liquids and dust.

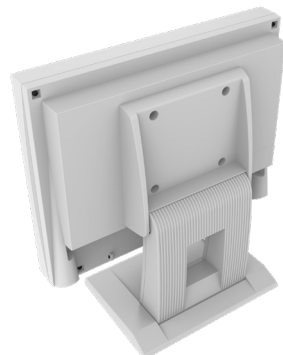

High Brightness for Clear Visibility

The maximum brightness of 320 cd/m² ensures the screen is clearly visible even in bright ambient environments. The brightness is adjustable to as low as 0.5 cd/m² for viewing in low ambient lighting conditions.

Intuitive Touch Operation

The monitor is equipped with an analog resistive touch panel that accepts touch input from gloved or bare hands, as well as styluses, making it flexible for a range of environments. This also makes it more resistant to dust and water compared to other touch technologies for increased durability.



DuraVision® FDX1502T

Complete Connection

The monitor is equipped with DisplayPort, HDMI, and D-Sub input terminals for flexible connection.

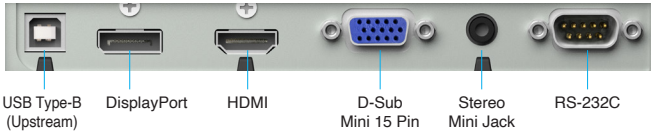

Built-In Speakers

The monitor is equipped with built-in stereo speakers for environments requiring audio.

Durability and Reliability

The monitor is built for 24-hour use and is backed by a 3-year manufacturer's warranty for long-term reliability.



Dimensions (Unit : mm)

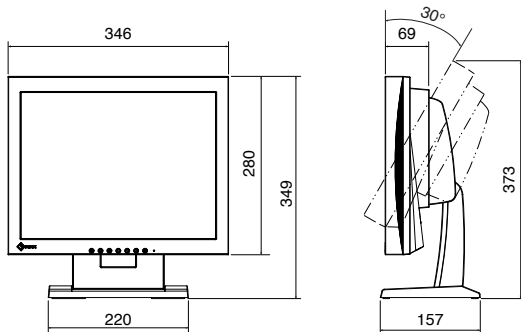

Specifications

Model Variation		FDX1502T-TBK: with stand, black FDX1502T-TGY: with stand, gray FDX1502T-FBK: without stand, black FDX1502T-FGY: without stand, gray FDX1502T-PBK: Panel Mount, black
Panel	Type	TN
	Backlight	LED
	Size	15.0" (38 cm)
	Native Resolution	1024 x 768 (4:3 aspect ratio)
	Viewable Image Size (H x V)	304.1 x 228.1 mm
	Pixel Pitch	0.297 x 0.297 mm
	Display Colors	16.77 million
	Viewing Angles (H / V, typical)	160° / 160°
	Brightness (typical)	320 cd/m ²
	Contrast Ratio (typical)	600:1
Response Time (typical)	8 ms (black-white-black)	
Touch Panel	Type	Analog resistive
	Touch Points	1
	Surface Treatment	Anti-Glare coating
	Communication Protocol	USB 2.0 / RS-232C
	Surface Hardness	2 H
Video Signals	Input Terminals	DisplayPort (HDCP 1.3), HDMI (HDCP 1.4), D-Sub mini 15 pin
	Digital Scanning Frequency (H / V)	31 - 49 kHz / 59 - 61 Hz
	Analog Scanning Frequency (H / V)	31 - 61 kHz / 55 - 76 Hz
	Sync Formats	Separate
USB	Upstream	USB 2.0: Type-B
Audio	Speakers	1 W + 1 W (FDX1502T-T/-F)
	Input Terminals	Stereo mini jack (FDX1502T-T/-F)
Power	Power Requirements	FDX1502T-T/-F: AC 100 - 240 V, 50 / 60 Hz FDX1502T-P: DC 12 V
	Typical Power Consumption	FDX1502T-T/-F: 5 W
	Maximum Power Consumption	FDX1502T-T/-F: 19 W FDX1502T-P: 16 W
	Power Save Mode	FDX1502T-T/-F: 0.4 W or less FDX1502T-P: 0.3 W or less
Features and Functions	Preset Modes	User1, User2, sRGB
Physical Specifications	Dimensions (Landscape, W x H x D)	346 x 349 x 157 mm
	Dimensions (Without Stand, W x H x D)	346 x 280 x 69 mm
	Dimensions (Panel Mount, W x H x D)	383 x 331 x 62 mm
	Net Weight	5.7 kg / 12.6 lbs
	Net Weight (Without Stand)	3.4 kg / 7.5 lbs
	Net Weight (Panel Mount)	3.8 kg / 8.4 lbs
	Tilt	30° Up, 0° Down
	Hole Spacing (VESA Standard)	FDX1502T-T/-F: 100 x 100 mm / 75 x 75 mm, M4, screw depth 3.0 - 10 mm FDX1502T-P: 100 x 100 mm / 75 x 75 mm, M4, screw depth 3.0 - 8 mm
Environmental Requirements	Operating Temperature	0 - 50°C
	Operating Humidity (R.H., non condensing)	20 - 90%
	Degree of Protection	FDX1502T-PBK: IP65 (front)
Certifications & Standards (Please contact EIZO for the latest information.)		FDX1502T-T/-F: CB, CE, UKCA, cTÜVus, FCC-B, CAN ICES-3 (B), TÜV/S, PSE, VCCI-B, RCM, RoHS, WEEE, CCC, EAC, China RoHS, BIS, India RoHS FDX1502T-P: CB, CE, UKCA, cTÜVus, FCC-B, CAN ICES-3 (B), TÜV/S, VCCI-B, RCM, RoHS, WEEE, CCC, EAC, China RoHS, BIS, India RoHS
Supplied Accessories (May vary by country. Please contact EIZO for details.)	Signal Cables	HDMI (2 m), D-Sub mini 15 pin (1.8 m)
	Others	FDX1502T-T: USB Type-A - USB Type-B cable (1.8m), Audio cable (2.1m), Setup manual, Cable clamper x 4
		FDX1502T-F: USB Type-A - USB Type-B cable (1.8m), Audio cable (2.1m), Setup manual, VESA mounting screw (M4 x 12 mm) x 4, Cable clamper x 4
Warranty		3 Years (24-hour use)

EIZO Corporation

153 Shimokashiwano, Hakusan, Ishikawa 924-8566 Japan
Phone: +81-76-277-6792
<https://www.eizoglobal.com>

EIZO, the EIZO logo, and DuraVision are registered trademarks of EIZO Corporation in Japan and other countries. The terms HDMI and HDMI High-Definition Multimedia Interface, and the HDMI Logo are trademarks or registered trademarks of HDMI Licensing, LLC in the United States and other countries. Windows is a registered trademark of Microsoft Corporation in the United States and other countries. All other company names, product names, and logos are trademarks or registered trademarks of their respective owners. Specifications are subject to change without notice.