



### Features ▶▶▶

- Conformal Coated for harsh railway standards
- Automatic MDI/MDI-X crossover for plug-and-play
- Store-and-forward architecture
- Full duplex IEEE 802.3x and half duplex backpressure flow control
- Each port supports both 10/100 Mbps speed auto negotiation
- Supports +12 V<sub>DC</sub> ~ +48 V<sub>DC</sub> power input
- Supports operating temperatures from -40 °C ~ +75 °C
- DIN-Rail Mounting

### Introduction

NS-208R Ethernet switch is designed for industrial applications, such as rolling stock, vehicle, and railway applications. Conformal coatings encapsulate circuit boards and their electronic components in order to prevent the ingress of moisture, fungus, dust and other environmental contaminants. After the coating is made on the switches, it provides environmental and mechanical protection to significantly extend the life of the components and circuitry to meet the challenges in severe industrial environments.

NS-208R provides a wide +12 V<sub>DC</sub> ~ +48 V<sub>DC</sub> power range to fit all the common power standards found in industrial automation, without external power converters. The wide power input lowers installation and maintenance costs.

### Comparison Table of 8-port 10/100 Mbps Ethernet Switch

Mode Name	NS-208	NSM-108	NS-208A	NSM-208A	NS-208R
Input Voltage Range	+10 V <sub>DC</sub> ~ +30 V <sub>DC</sub>		+12 V <sub>DC</sub> ~ +48 V <sub>DC</sub>		
Casing	Plastic	Metal	Plastic	Metal	Plastic
Installation	DIN-Rail Mounting	DIN-Rail Mounting or Wall Mounting		DIN-Rail Mounting	
Dimensions (W x L x H) (Unit: mm)	64 x 98 x 118	73 x 102 x 132	31 x 113 x 157	25 x 119 x 168	64 x 98 x 118
Remarks	-		Cost-effective		Conformal Coating

## Specifications

<b>Technology</b>	
Standards	IEEE 802.3, 802.3u, 802.3x
Processing Type	Store & forward; wire speed switching
MAC Addresses	2048
Memory Bandwidth	3.2 Gbps
Frame Buffer Memory	512 Kbit
Flow Control	IEEE 802.3x flow control, back pressure flow control
<b>Interface</b>	
RJ-45 Ports	10/100 Base-T(X) auto negotiation speed, F/H duplex mode, and auto MDI/MDI-X connection
LED Indicators	Power, Link/Act, 10/100M
Ethernet Isolation	1500 V <sub>rms</sub> 1 minute
EMS Protection	Yes
<b>Power Input</b>	
Input Voltage Range	+12 V <sub>dc</sub> ~ +48 V <sub>dc</sub>
Power Consumption	0.15 A @ 24 V <sub>dc</sub>
Protection	Power reverse polarity protection
EMS Protection	Yes
Connector	5-Pin Removable Terminal Block
<b>Mechanical</b>	
Casing	Plastic (Flammability UL 94V-0)
Dimensions (W x L x H)	64 mm x 98 mm x 118 mm
Installation	DIN-Rail Mounting
<b>Environment</b>	
Operating Temperature	-40 °C ~ +75 °C
Storage Temperature	-40 °C ~ +85 °C
Ambient Relative Humidity	10% ~ 90% RH, non-condensing

## Applications



## Dimensions (Units: mm)

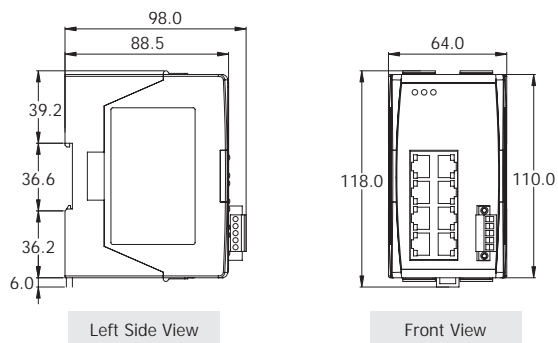

## Ordering Information

NS-208R CR	Conformal Coated 8-port Industrial 10/100 Mbps Ethernet Switch (RoHS)
------------	---

## Accessories

MDR-60-48	48 V/1.25 A, 60 W Power Supply with DIN-Rail Mounting
DIN-KA52F-48	48 V/0.52 A, 25 W Power Supply with DIN-Rail Mounting
KA52F-48	48 V/0.52 A, 25 W Power Supply