

7188XB Series

Hardware User's Manual

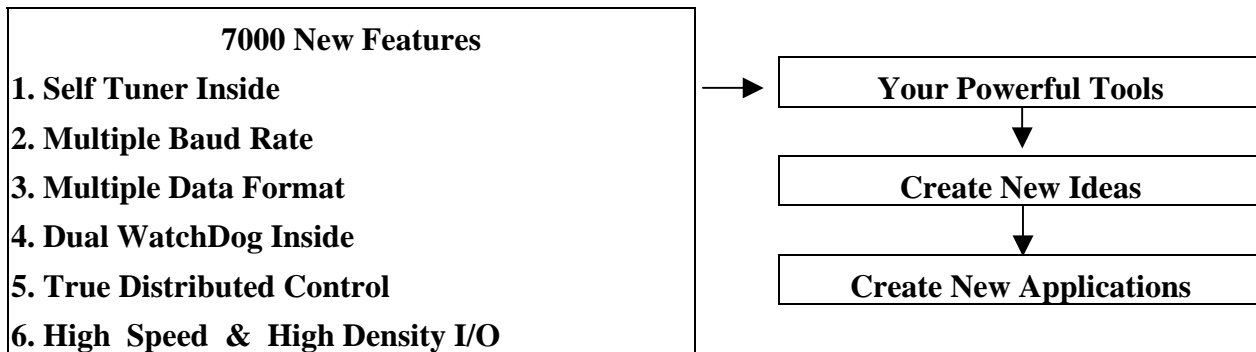

Warranty

All products manufactured by ICP DAS are warranted against defective materials for a period of one year from the date of delivery to the original purchaser.

Warning

ICP DAS assume no liability for damages consequent to the use of this product. ICP DAS reserves the right to change this manual at any time without notice. The information furnished by ICP DAS is believed to be accurate and reliable. However, no responsibility is assumed by ICP DAS for its use, nor for any infringements of patents or other rights of third parties resulting from its use.

Copyright

Copyright 2000 by ICP DAS. All rights are reserved.

Trademark

The names used for identification only may be registered trademarks of their respective companies.

Table of Contents

1. INTRODUCTION	3
1.1 FEATURES	7
1.2 PIN ASSIGNMENT	11
1.3 SPECIFICATIONS	13
1.4 BLOCK DIAGRAM.....	15
1.5 WIRING DIAGRAMS FOR APPLICATION.....	16
1.6 COMPARISON TABLE.....	21
2. OPERATION PRINCIPLES	24
2.1 SYSTEM MAPPING.....	24
2.2 HOW TO DEBUG USER'S PROGRAMS	26
2.3 HOW TO DOWNLOAD USER'S PROGRAM.....	27
2.4 USING THE DOWNLOAD_PORT AS A COM PORT	27
2.5 COM PORTS COMPARISON.....	28
2.6 THE RS-485 PORT & SELF-TUNER ASIC.....	29
2.7 USING RED LED & 7-SEG LED DISPLAY.....	30
2.8 USING RTC & NVSRAM.....	30
2.9 USING EEPROM	31
2.10 USING THE WATCHDOG TIMER	31
2.11 USING THE I/O EXPANSION BUS	32
3. APPLICATIONS	41
3.1 EMBEDDED CONTROLLERS	41
3.2 LOCAL REAL TIME CONTROLLER.....	42
3.3 REMOTE LOCAL CONTROLLER.....	43
3.4 I/O EXPANSION OF PLC APPLICATIONS	44
3.5 RADIO MODEM APPLICATIONS	45
3.6 USING 4 COM PORT APPLICATION-1	46
3.7 USING 4 COM PORT APPLICATION-2.....	47

1. Introduction

The 7188XB series is a series of expandable embedded controllers designed for industry applications. They can be used to replace the PC or PLC in harsh environments. The 7188X series can be ordered as following:

Order Items	Module name	O. S.
7188XA(D)	Expandable Embedded controller	MiniOS7
7188XB(D)	Expandable Embedded controller	MiniOS7
7188XC(D)	Expandable Embedded controller	MiniOS7
7XXX	7XXX without 7-SEG display	MiniOS7
7XXXD	7XXX with 7-SEG display	MiniOS7

The 7000 series modules have been very successful during the past three years. Over one hundred thousand modules have been shipped to locations all over the world. The reasons for our success are given as follows:

- Time-to-market & cost-effective solutions
- Durable, stable, flexible, & easy to program
- Over 50 various I/O modules are supported
- Can be used in harsh, noisy industry environments

However, even though the 7000 family is so versatile, there are some applications that cannot be initially solved, such as:

- High speed applications
- Special hardware requirement applications
- Special software requirement applications
- A combinations of special hardware & software applications

Therefore, we developed an I/O expansion bus for the 7188X family to solve all the above applications above. The I/O expansion bus can be used to implement various I/O functions such as D/I, D/O, A/D, D/A, Timer/Counter, UART, flash memory, battery backup SRAM, AsicKey & other I/O functions. **Nearly all kinds of I/O functions can be implemented by this bus.**

The I/O expansion bus includes serial & parallel interface. The parallel interface is very similar to ISA bus, so the user can move the old ISA bus design to the I/O expansion bus with very little modification.

Furthermore, the I/O pins of the serial bus are programmable. They can be programmed as D/I, or D/O. Some pins can be configured to D/I or D/O or timer input or timer output. There are many serial interface devices today. The features of these serial devices are given as follows:

- Smaller size compared to parallel devices
- Lower cost compared to parallel devices
- Easier to design for isolation applications

The serial interface of the I/O expansion bus can link to these serial devices very easily. The design of the I/O Expansion Bus makes the idea of a “Customized 7000 Module” come true. The features of a “Customized 7000 Module” are given as follows:

- **7188X+X?? → Single module solution → a “Customized 7000 Module”**
- 7000 compatible command sets & RS-485 networking
- Easy hardware/software interface for user to design & manufacture their own special hardware & software
- Time-to-market ODM solution for user’s special requirements (any high speed, complex or combined functions of D/I/O, A/D, D/A,.., etc.)
- Durable, stable, flexible, time-to-market & cost-effective total solution.

Some “Customized 7000 Modules” are available as follows:

- IKIT-09: LONG TIME DATA LOGGER=7188XBD+X800
- IKIT-10: LONG TIME 7000 LOGGE=7188XBD+X600

- IKIT-11: ANALOG SIGNAL CONTROLLER=7188XBD+X801
- More “Customized 7000 Modules” will be ready in the near future

The 7188XB(D) has 14 user-defined pins. But the 7188X(B) don't support the reconfiguration-resistor. So the user-defined pins of the 7188X family are given as follows:

	User defined pins	Reconfiguration pins	Customized I/O pins
7188XA(D)	0	0	0+0=0
7188XB(D)	14	0	14+0=14
7188XC(D)	3	5	3+5=8

Refer to “I/O Expansion Bus in 7188X/7188E User’s Manual” for more information.

Refer to “ 7000 Bus Converter User Manual ” chapter 1 for more information as follows:

1.1 7000 Overview

1.2 7000 Related Documentation

1.3 7000 Common Features

1.4 7000 System Network Configuration

1.5 7000 Dimensions

Package List

In addition to this manual, the package includes the following items:

- One 7188XB series hardware module
- One hardware manual (this manual)
- One release note
- One software utility disk or CD
- One download cable → CA0910 for 7188XB

Note

If any of these items are missing or damaged, contact the local distributors for more information. Save the shipping materials and cartons in case you want to

ship in the future.

Release Note

It is recommended to read the release note first. All important information will be given in release note as follows:

- Where the “7188X/7521 Software User’s Manual” is
- Where the “I/O Expansion Bus for 7188X/7188E User’s Manual” is
- Where the software driver & diagnostic programs are

1.1 Features

1.1.1 General features

- AMD's embedded CPU, Am188™ES: 40M
- SRAM: 256K bytes
- Flash ROM: 512K bytes
- Built-in EEPROM
- Built-in RTC&NVRam
- Built-in COM port: COM1, COM2
- 64-bit hardware unique serial number inside
- User defined D/I/O
- Built-in 5-digit LED display interface
- COM driver support interrupt & 1K QUEUE input buffer
- Built-in I/O expansion bus interface
- Built-in watchdog timer for harsh environments
- Built-in power protection circuit
- Built-in RS-485 network protection circuit
- Built-in self-tuner ASIC controller on RS-485 port
- Program download from PC
- Built-in OS: MiniOS7 of ICP DAS
- Operating temperature: -25°C to +75°C
- Can be used in harsh environments for industry applications

NOTE:

1. ODM wanted

2. "Customized 7000 Modules" wanted

1.1.2 What is MiniOS7?

The MiniOS7 is an embedded O.S. designed for the 7188X/7521 series. **Developed by ICP DAS Co. Ltd;** It is used to replace the ROMDOS used in the 7188 series. Several brands of DOS have been created by various companies. In all cases, DOS--whether PC-DOS, MS-DOS, or ROM-DOS--is a set of commands or code which tells the computer how to process information. DOS runs programs, manages files, controls information processing, directs input and output, and performs many other related functions. **The MiniOS7 provides the equivalent functions of ROMDOS while, in addition, providing user specific functions for the 7188X/7521 family.**

Comparison table between MiniOS7 & ROM-DOS?

	MiniOS7	ROMDOS
Power up time	0.1 sec	4 ~ 5 sec
More compact size	<64K bytes	64K bytes
Supports I/O expansion bus	Yes	No
Supports AsicKey	Yes	No
Flash ROM management	Yes	No
O.S. update (download)	Yes	No
Built-in hardware diagnostic functions	Yes	No
Direct control of the 7000 series modules	Yes	No
Customer ODM functions	Yes	No
Free charge	Yes	No

Note: We reserve the right to change the specifications of MiniOs7 without notice

1.1.3 What is the 64-bit hardware unique serial number?

The 7188XB equips a 64-bit hardware unique hardware serial number onboard. This number is unique & cannot be shared by any two 7188XBs. The application software can check this number for illegal copies. It is the most low cost protection mechanism the 7188XB family currently has

1.1.4 What is the Self-Tuner ASIC?

The 2-wire RS-485 port is designed to directly drive the 7000 series modules. It is a half-duplex 2-wire RS-485 network. Send/receive directional control in a 2-wire RS-485 network is very important. Therefore, the 7188X/7521 series equip a Self-Tuner ASIC controller for all RS-485 ports. The Self-Tuner ASIC controller will auto detect & control the send/receive direction of the RS-485 network. Consequently, the application program does not have to worry about the send/receive directional control of the RS-485 network.

1.1.5 What is the I/O Expansion Bus?

The 7188XB support I/O expansion buses. The I/O expansion bus can be used to implement various I/O functions such as D/I, D/O, A/D, D/A, Timer/Counter, UART, flash memory, battery backup SRAM, AsicKey & other I/O functions. Nearly all kinds of I/O functions can be implemented on this bus.

1.1.6 What is the AsicKey?

The I/O expansion bus supports AsicKey. The AsicKey equips a complex machine for validation checking. Included in this is 128 bytes of private data for the same purpose. It provides very strong protection against illegal copies. Every legal user has a unique AsicKey & unique software library, the user can self check this key, or the software library will check the key automatically. In this main, it is nearly impossible to remove the AsicKey protection.

1.1.7 7188XB = Addressable RS-232 Converter?

The 7188XB is designed as an embedded controller. Therefore, any software can be downloaded into it. If the firmware for an "Addressable RS-232 Converter" is downloaded into a 7188XB, they will act as an "Addressable RS-232 Converter".

1.2 Pin Assignment

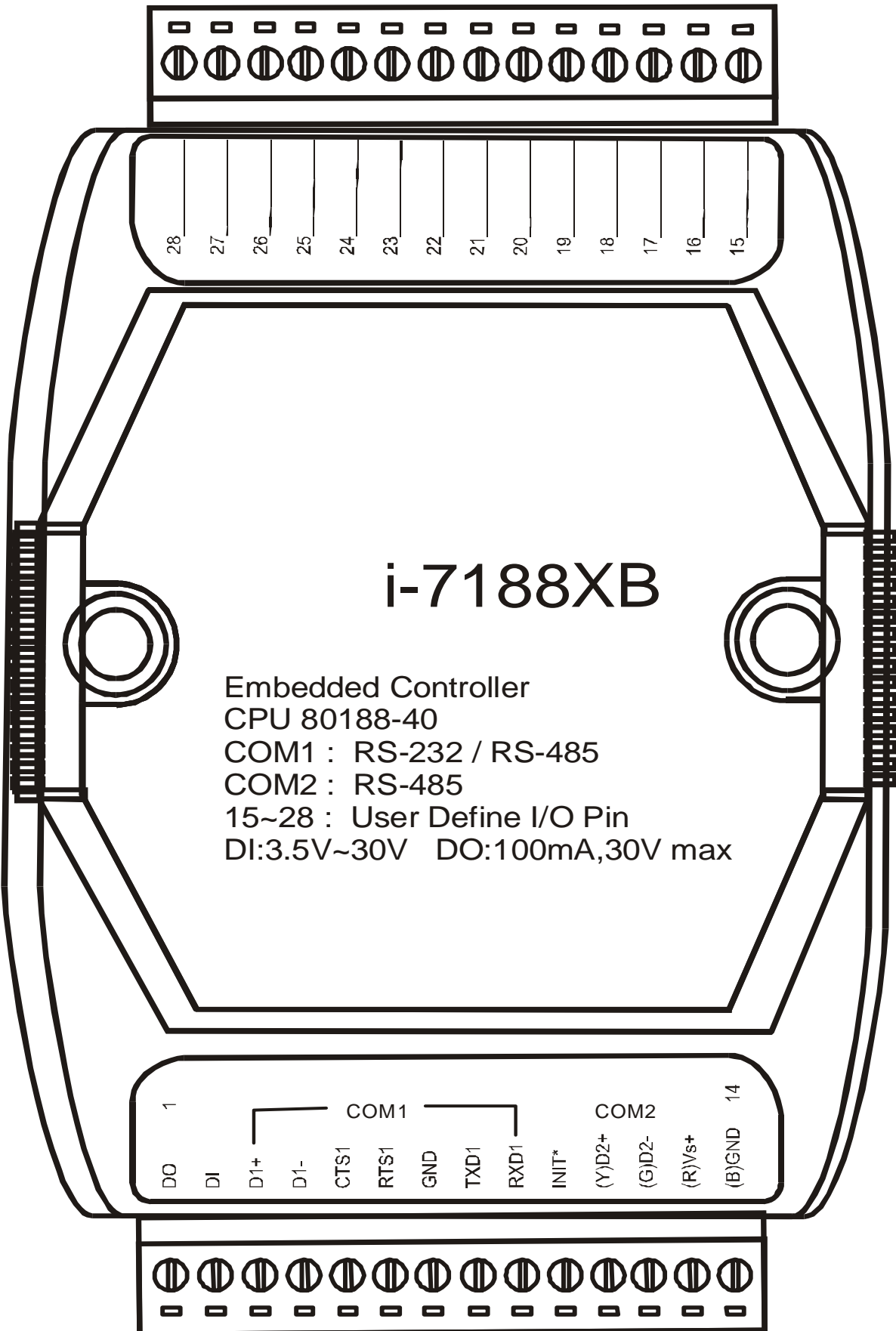

Pin assignment of bottom 14-pin screw terminal block(7188XB/7188XBD):

Pin	Name	Description
1	DO	100 mA, 30V max.
2	DI	3.5V ~ 30V
3	D1+	DATA+ pin of COM1 (RS-485)
4	D1-	DATA- pin of COM1 (RS-485)
5	CTS1	Clear To Send of COM1 (RS-232)
6	RTS1	Request To Send of COM1 (RS-232)
7	GND	Signal ground of RS-232
8	TXD1	Transmits Data of COM1 (RS-232)
9	RXD1	Receives Data of COM1 (RS-232)
10	INIT*	Initial pin, 3.5V ~ 30V
11	D2+	DATA+ pin of COM2 (RS-485)
12	D2-	DATA- pin of COM2 (RS-485)
13	+VS	V+ of power supply (+10 to +30VDC unregulated)
14	GND	GND of power supply

Note: The COM1 can be used as a RS-232 port or a RS-485 port. It is not recommended to use both RS-232 & RS-485 at the same time.

Pin assignment of top 13-pin screw terminal block(7188XB/7188XBD):

15	Pin 15	User defined pin 15
16	Pin 16	User defined pin 16
17	Pin 17	User defined pin 17
18	Pin 18	User defined pin 18
19	Pin 19	User defined pin 19
20	Pin 20	User defined pin 20
21	Pin 21	User defined pin 21
22	Pin 22	User defined pin 22
23	Pin 23	User defined pin 23
24	Pin 24	User defined pin 24
25	Pin 25	User defined pin 25
26	Pin 26	User defined pin 26
27	Pin 27	User defined pin 27
28	Pin 28	User defined pin 28

1.3 Specifications

General environment

- Operating temperature: -25°C to +75°C
- Storage temperature:-40°C to +85°C
- Humidity: 0 to 90 %
- Built-in Watch Dog Timer (1.6 seconds)
- Built-in power protection & network protection circuit
- Program downloadable from PC
- Built-in I/O expansion bus interface

1.3.1 Specifications of 7188XB & 7188XBD

System

- Module name: embedded controller
- CPU: Am188TMES, 40M Hz
- SRAM: 256K bytes
- FLASH ROM: 512K bytes
- COM port: COM1, COM2
- Built-in RTC, NVRAM, EEPROM, D/I, D/O
- User defined pins:14, pin-15 ~ pin-28
- Supports I/O Expansion Bus
- **Program download port: COM1**

Real Time Clock

- Year-2000 compliance
- Seconds, minutes, hours, date of the month
- Month, year, valid **from 1980 to 2079**
- NVSRAM: 31 bytes, battery backup, data valid up to 10 years

EEPROM

- 2048 bytes (8 blocks, each block has 256 bytes)
- Data retention > 100 years
- 1,000,000 erase/write cycles

Flash Memory

- 512K bytes
- Erase unit is one sector(64K bytes)

- 100,000 erase/write cycles

D/I: 1 channel

- High:3.5V ~ 30V, Low:0 ~ 1V

D/O: 1 channel

- **100 mA, 30V max.**

COM1

- RS-232 or RS-485
- RS-232: TXD,RXD,RTS,CTS,GND
- RS-485: D1+, D1-, self-tuner ASIC inside
- Communication speed: 115200 max.

COM2

- RS-485: D2+, D2-, self-tuner ASIC inside
- Communication speed: 115200 max.

Display

- 7-segment LED: 5-digit (for 7188XBD)

Power

- Power requirements: 10 to 30VDC(non-regulated)
- Power consumption: 2.0W for 7188XB
3.0W for 7188XBD

For ODM User

- SRAM can be 512K max.
- COM2 can be 3000V isolated
- EEPROM can be 32K bytes

1.4 Block Diagram

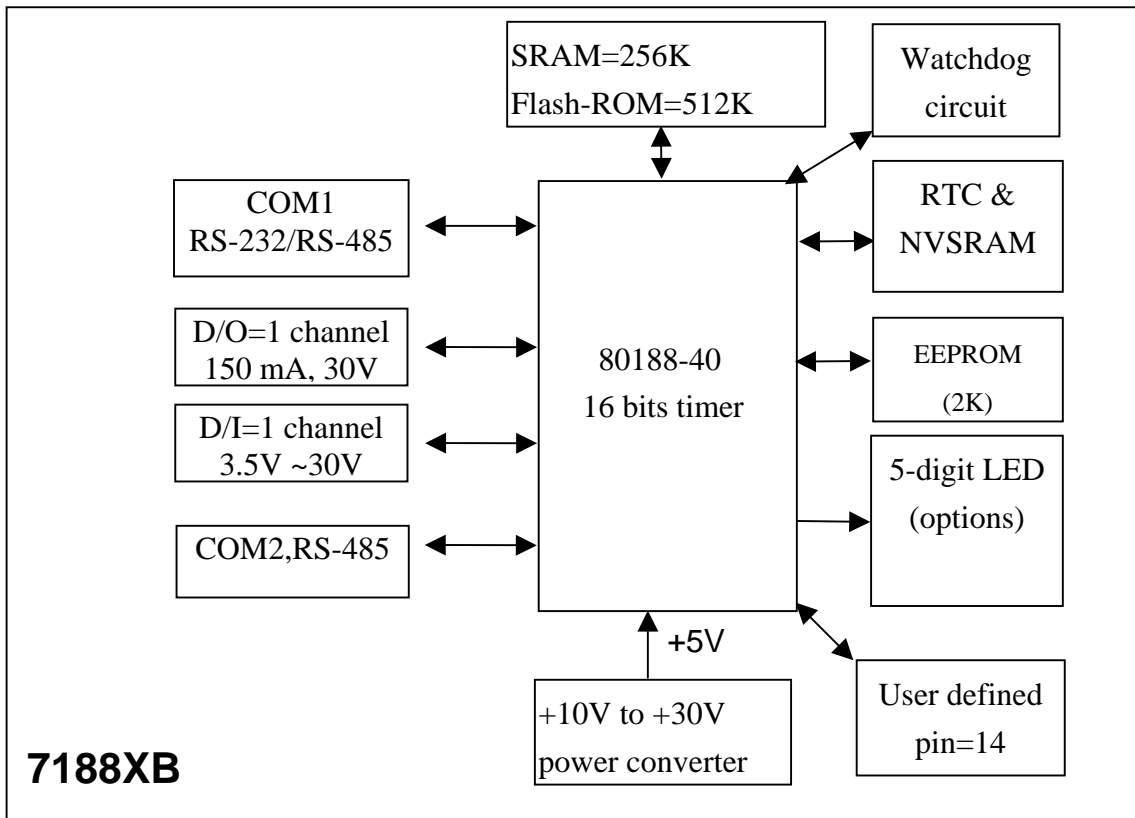

1.5 Wiring Diagrams for Application

1.5.1 Program download

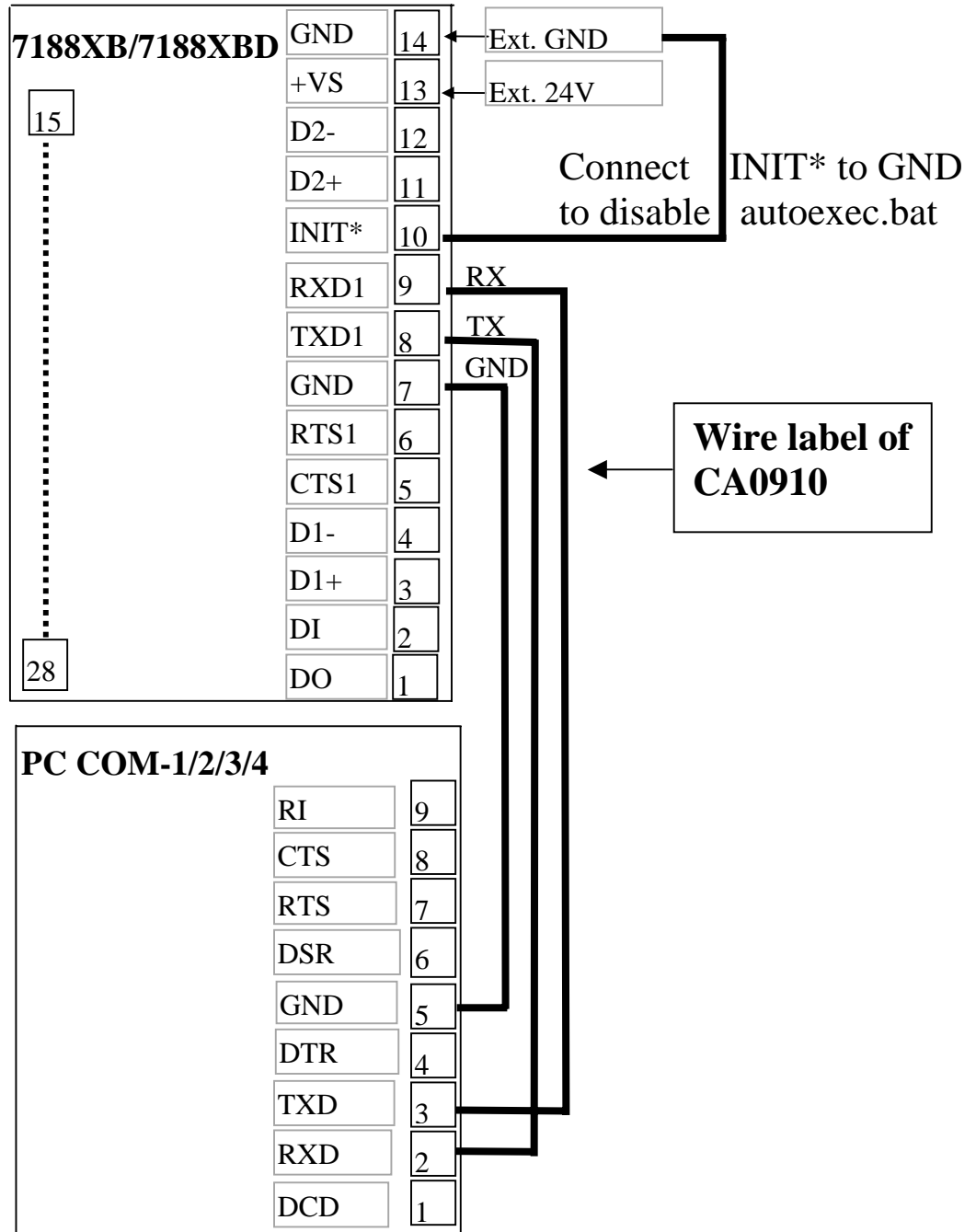

Note:

- There are 3 wires in the download cable
- Connect the wire-1, label RX, to pin-8 of 7188XB
- Connect the wire-2, label TX, to pin-7 of 7188XB

**Program
download
wire
connection**

- Connect the wire-3, label GND, to pin-6 of 7188XB
- Connect the DB-9 of download cable to PC COM-1/2 port

1.5.2 Using a 3-wire RS-232 port

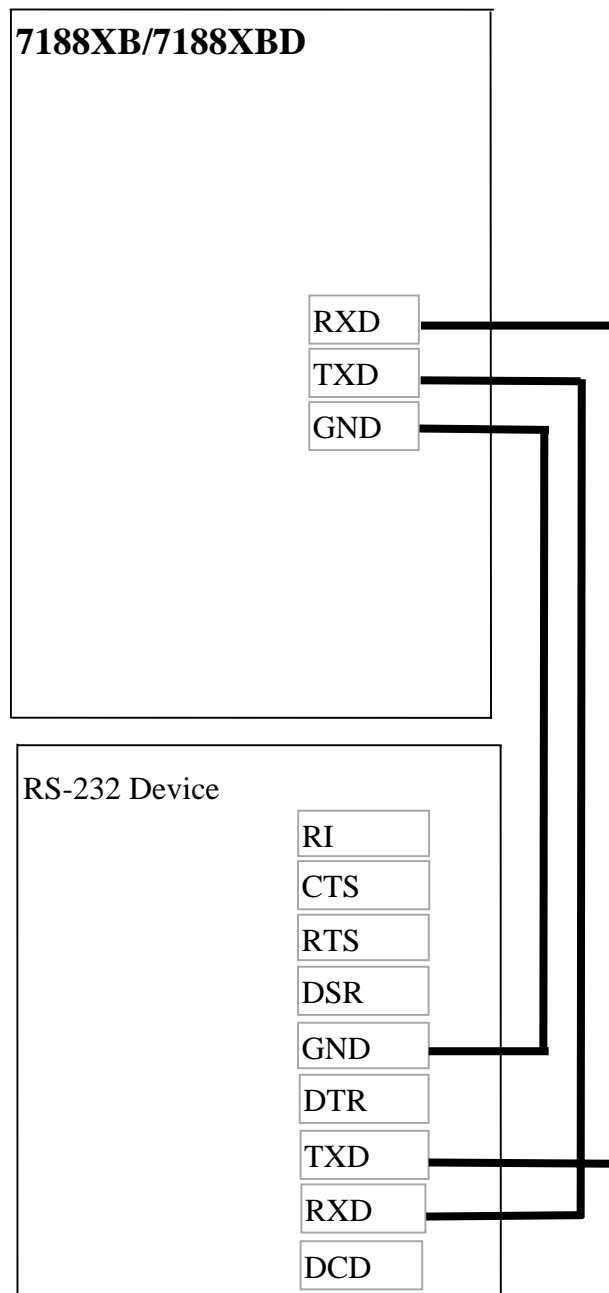

There are 3 wires as following:

- Connect RXD to TXD of RS-232 device
- Connect TXD to RXD of RS-232 device
- Connect GND to GND of RS-232 device

1.5.3 Using a 5-wire RS-232 port

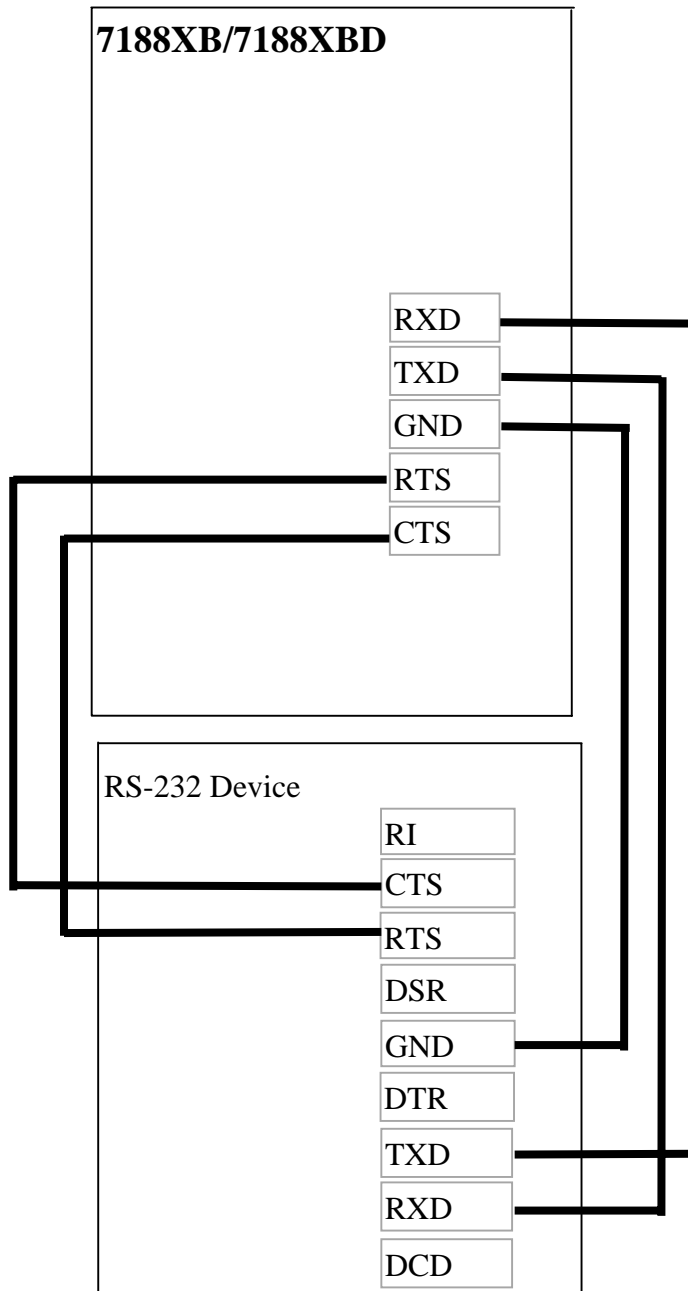

There are 5 wires as follows:

- Connect RXD to TXD of RS-232 device
- Connect TXD to RXD of RS-232 device
- Connect RTS to CTS of RS-232 device
- Connect CTS to RTS of RS-232 device
- Connect GND to GND of RS-232 device

1.5.4 Using a RS-485 port

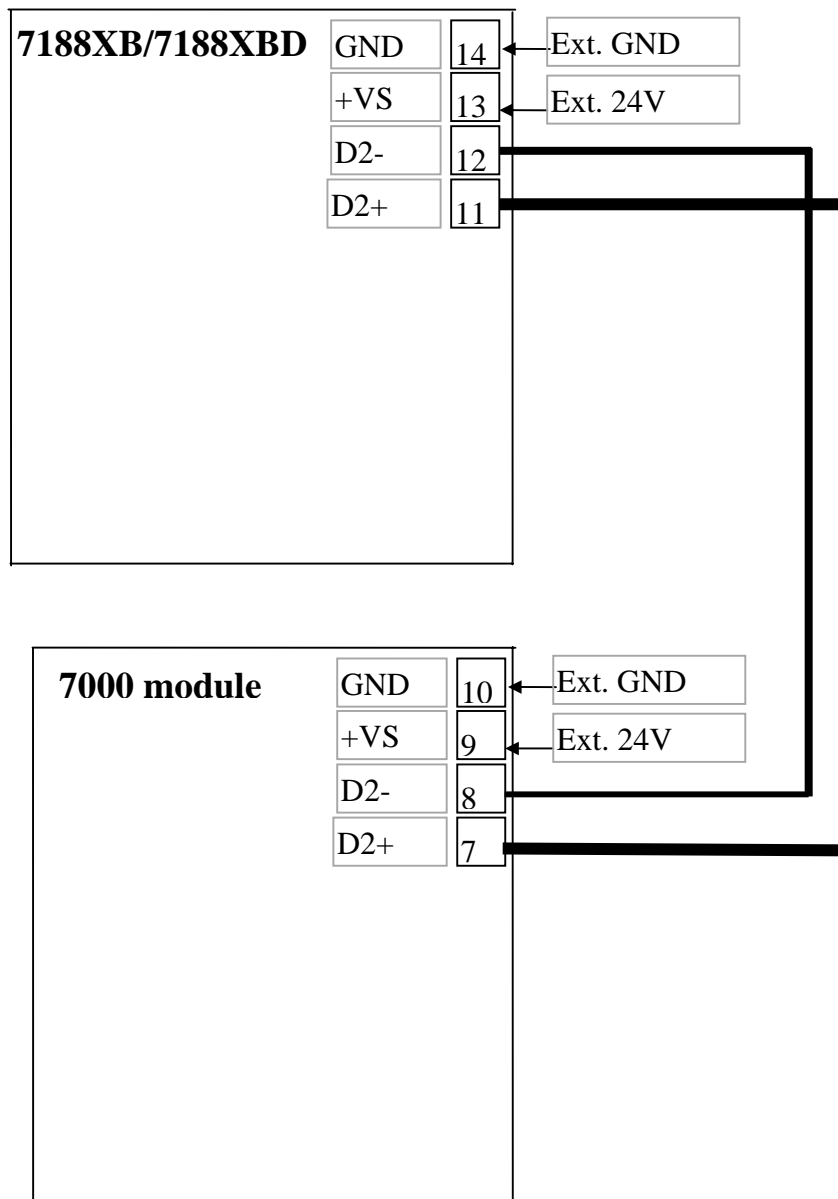

Note:

- The RS-485 interface can directly drive 256 sets of 7000 modules without a repeater

1.6 Comparison Table

Comparison table between the 7188 & the 7188X series:

	7188(D)	7188XC(D)	7188XB(D)	7188XA(D)
CPU clock	80188, 40M Hz	80188, 20M Hz	80188, 40M Hz	80188, 40M Hz
SRAM	256K	128K	256K	512K
Flash ROM	256K/512K	256K (512K for ODM)	512K	512K
COM1	RS-232 with modem control or RS-485	RS-232 or RS-485 with self-tuner inside	RS-232 or RS-485 with self-tuner inside	RS-232 with modem control or RS-485 with self-tuner inside
COM2	RS-485,	RS-485 with self-tuner inside	RS-485 with self-tuner inside	RS-485 with self-tuner inside, 3000V isolation
COM3	RS-232 (txd,rxd)	No Com3	No Com3	RS-232 (txd,rxd)
COM4	RS-232 (txd,rxd)	No Com4	No Com4	RS-232 (txd,rxd)
User defined pins	0	3	14	0
Modem control	COM1	No	No	COM1
RTC	Yes	No	Yes	Yes
64 bits hardware unique serial number	No	No	Yes	Yes
EEPROM	2K bytes	2K bytes	2K bytes	2K bytes
D/I(3.5V~30V)	0	3 channels	1 channel	2 channels
D/O(150mA, 30V)	0	3 channels	1 channel	2 channels
I/O expansion bus	No	Yes	Yes	Yes
Support AsicKey	No	Yes	Yes	Yes
Operation system	MiniOS7	MiniOS7	MiniOS7	MiniOS7
Programming language	TC/MSC/BC	TC/MSC/BC	TC/MSC/BC	TC/MSC/BC
Program download	COM4	COM1	COM1	COM4

Comparison table of 7188E series:

	7188EA(D)	7188EX(D)	7188E2(D)
CPU clock	80188, 40M Hz	80188, 40M Hz	80188, 40M Hz
SRAM	512K	512K	256K
Flash ROM	512K	512K	256K
COM1	RS-232 or RS-485 with self-tuner inside	RS-232 or RS-485 with self-tuner inside	RS-232 or RS-485 with self-tuner inside
COM2	RS-485 with self-tuner inside, non-isolated	RS-485 with self-tuner inside, non-isolated	RS-485 with self-tuner inside, non-isolated
RTC	Yes	Yes	No
64 bits hardware unique serial number	Yes	Yes	No
EEPROM	2K bytes	2K bytes	2K bytes
D/I(3.5V~30V)	6 channels	0	0
D/O(150mA, 30V)	7 channels	0	0
User Defined pins	0	14	0
I/O expansion bus	Yes (but used by system)	Yes	No
Support AsicKey	Yes	Yes	No
Operation system	MiniOS7	MiniOS7	MiniOS7
Programming language	TC/MSC/BC	TC/MSC/BC	TC/MSC/BC
Program download	COM1	COM1	COM1
Ethernet interface	10BaseT	10Base-T	10BaseT

Comparison table of CPU modules:

	<i>Description</i>
7188	Embedded Controller
7188XA	Expandable Embedded Controller with I/O Expansion Bus
7188XB	Expandable Embedded Controller with I/O Expansion Bus, high I/O expansion
7188XC	Expandable Embedded Controller with I/O Expansion Bus, low cost
7521/22/23	Embedded Communication Controller, 1/2/3 channels
7188EA	Embedded Internet/Ethernet Controller, DI * 6 channels, DO * 7 channels
7188EX	Embedded Internet/Ethernet Controller with I/O Expansion Bus
7188E1	Internet Communication Controller, RS232 * 1
7188E2	Internet Communication Controller, RS232 * 1 + RS485*1
7188E3	Internet Communication Controller, RS232 * 1 + RS485 * 1+RS422/485 * 1 + DI * 4 +DO * 4
7188E4	Internet Communication Controller, RS232 * 3 + RS485*1
7188E5	Internet Communication Controller, RS232 * 4 + RS485*1
7188E8	Internet Communication Controller, RS232 * 7 + RS485*1

2. Operation Principles

2.1 System Mapping

2.1.1 Address Mapping of the 7188XB

Device	Address mapping
Flash ROM	256K: from C000:0000 to F000: FFFF 512K: from 8000:0000 to F000: FFFF
SRAM	128K: from 0000:0000 to 1000:FFFF 256K: from 0000:0000 to 3000:FFFF
COM1 BASE	0XFF80 to 0XFF88
COM2 BASE	0XFF10 to 0XFF18

Interrupt No.	Interrupt mapping
0	Divided by zero
1	Trace
2	NMI
3	Break point
4	Detected overflow exception
5	Array bounds exception
6	Unused opcode exception
7	ESC opcode exception
8	Timer 0
9	Reserved
0A	DMA-0
0B	DMA-1
0C	\INT0 of I/O expansion bus
0D	\INT1 of I/O expansion bus
10	XB: \INT4 of I/O expansion bus XC: Reserved
11	COM2

12	Timer 1
13	Timer 2
14	COM1

2.1.2 Address Mapping of the X505, X506, X507

		X505	X506	X507
DI		N/A	N/A	0
DO		N/A	N/A	0
COM3	BASE	0X10	0X10	0X10
	INT	INT0	INT0	INT0
COM4	BASE	0X18	0X18	N/A
	INT	INT1	INT0	N/A
COM5	BASE	0X20	0X20	N/A
	INT	INT4	INT1	N/A
COM6	BASE	N/A	0X28	N/A
	INT	N/A	INT1	N/A
COM7	BASE	N/A	0X30	N/A
	INT	N/A	INT4	N/A
COM8	BASE	N/A	0X38	N/A
	INT	N/A	INT4	N/A

2.2 How to Debug User's Programs

The **download_ports** of the 7188XB are given as follows:

- 7188XB → Use **COM1**

When the 7188XB series is powered-up, it will initialize the **download_port** to the following configuration:

- **Start-bit=1, data-bit=8, stop-bit=1, no parity**
- **Baud rate = 115200 BPS**

Then, the 7188XB will send all power-up information to the **download_port**. The user will see all power-up messages as follows:

- Power-off PC & 7188XB
- Install the download cable between **download_port** of 7188XB & COM1 of PC (refer to Sec. 1.6)
- Power-up PC & Run 7188X.EXE
- Power-up 7188XB
- All power-up message will be shown on the monitor of the PC

After the power-up stage, the 7188XB will use the **download_port** as its standard input/output. So the standard output of 7188XB will be shown on the PC's monitor. If the user presses any key on the PC's keyboard, this key will be sent to the 7188XB as standard input. Therefore the keyboard & monitor of PC can be used as standard input & output of the 7188XB as follows:

- Use 7188X.EXE as a bridge between the 7188XB & PC
- Run 7188X.EXE in PC to set up this bridge
- **Keyboard of PC → standard input of 7188XB**
- **Monitor of PC → standard output of 7188XB**

In this way, the 7188XB can read data from the keyboard & display it on the monitor. So program debugging will be more convenient & effective.

Note: 7188X.EXE is included on the companion floppy disk/CD.

2.3 How to Download User's Program

Refer to Sec. 2.2 to find the **download_port** first.

The user can download the program into the 7188XB as follows:

- Power-off PC & the 7188XB
- Install the download cable between **download_port** of the 7188XB & COM1 of PC (refer to Sec. 1.6.1)
- Power-up PC & Run 7188X.EXE
- Power-up the 7188XB
- All power-up messages will be shown on the monitor of the PC
- Key-in "load", press Enter key, & wait for system request message
- Press Alt-E, the screen will ask you to input filename,
- Key-in the filename & press Enter key, the file will be download into the 7188XB
- Key-in the filename & press Enter. This will start to execute this file
- Pressing Alt & X at the same time will quit the 7188X.EXE

2.4 Using the download_port as a COM port

The user can use the **download_port** of the 7188XB series as a general purpose RS-232 port as follows:

- Download user's program & autoexec.bat to the 7188XB first.
- Power off the 7188XB & remove the download the cable from PC.
- If they are connected, disconnect the INIT*-pin from GND-pin of the 7188XB
- Power on the 7188XB (no standard input, no standard output, no debug information)
- Install the download cable between new RS-232 device & **download_port** of the 7188XB
- Initialize the **download_port** to new configuration.
- The **download_port** is a general purpose RS-232 port now.
- Refer to "7188X Software User's Manual" for demo programs

2.5 COM ports Comparison

The COM port of the 7188XB series can be RS-232 or RS-485 as follows:

type	Pins name
2-wire RS-485	Data+, Data-
3-wire RS-232	Txd,Rxd,Gnd
5-wire RS-232	Txd,Rxd,Gnd,Rts,Cts
9-wire RS_232	Txd,Rxd,Gnd,Rts,Cts,Dcd,Dtr,Dsr,Ri

The COM ports of the 7188XB are given as follows:

COM port	Hardware
COM1	80188's on-chip UART-0, 5-wire RS-232 & 2-wire RS-485
COM2	80188's on-chip UART-1, 2-wire RS-485

2.6 The RS-485 Port & Self-Tuner ASIC

The 2-wire RS-485 port is designed to directly drive 7000 series modules. It is a half-duplex 2-wire RS-485 network. Send/receive directional control in a 2-wire RS-485 network is very important. Therefore, the 7188X series equip a Self-Tuner ASIC controller for all RS-485 ports. The Self-Tuner ASIC controller will auto detect & control the send/receive direction of the RS-485 network. In this main, the application program does not have to worry about the send/receive direction control of the RS-485 network. For example, the software program for one-to-one communication is nearly the same.

```

ToCom(port, sent_data);      /* send one sent_char to RS-232/RS-485 */
                             /* no direction control */
while IsCom(port);          /* wait one echo_char from RS-232/RS-485 */
echo_data=ReadCom(port);    /* read this echo_data */
    
```

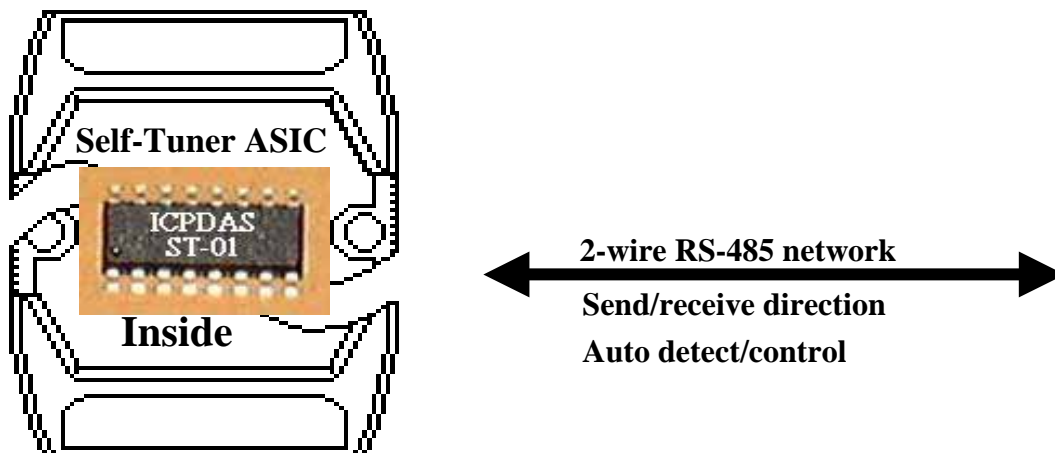
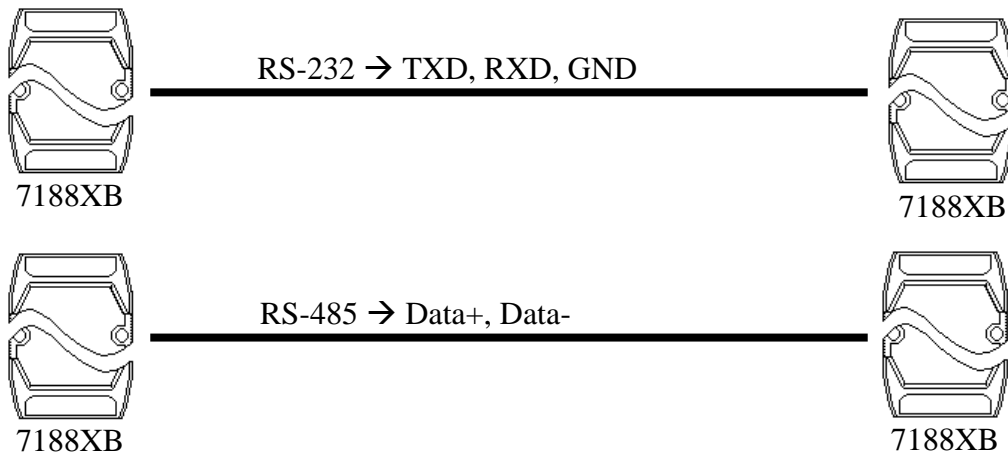

2.7 Using Red LED & 7-SEG LED Display

The red LED of the 7188XB series can be turned-ON or turned-OFF by its software program. The 5 digits of the seven-segment LED are also programmable. **The 5-digit LED is very useful in real world applications.** It can be used to replace the monitor & touch-screen for many applications.

2.8 Using RTC & NVSRAM

The RTC & NVSRAM are located on the same chip. There is a Li-battery to backup the RTC & NVSRAM for 10 years. The features of the RTC are given as follows:

- MiniOS7 supports RTC time & date
- Seconds, minutes, hours, date of the month
- Month, day of week, year, Leap year valid up to 2079
- NVSRAM: 31 bytes, data valid for 10 years

Note1: only 7188XA & 7188XB support RTC & NVRAM.

2.9 Using EEPROM

The EEPROM is designed to store the data which is not changed very frequently. This data is given as follows:

- Module ID, configuration settings
- COM port configuration settings
- Small databases

The erase/write cycle of the EEPROM is limited, the user should not change the EEPROM frequently for testing. The EEPROM can **erase/write in single byte**, so it is very useful in real world applications.

2.10 Using the Watchdog Timer

The watchdog timer of the 7188XB series is fixed at 1.6 sec. **When the 7188XB is powered up, the watchdog timer will be always enabled.** If the 7188XB do not refresh the watchdog timer every 1.6 seconds, the watchdog will RESET the 7188XB.

The MiniOS7 of the 7188XB will automatically refresh the watchdog after power up. The user program can call the software driver to tell MiniOS7 to stop refreshing the watchdog timer, then the user program must refresh the watchdog timer. If the user program does not refresh the watchdog timer every 1.6 seconds, the watchdog timer will RESET the 7188XB.

2.11 Using the I/O Expansion Bus

The 7000 series modules have been very successful in during the past three years. Over one hundred thousand modules have been shipped to locations all over the world. The reasons for our success is given as follows:

- Time-to-market & Cost effective solutions
- Durable, Stable, Flexible & Easy programming
- Over 50 Various I/O Modules are supported
- Can be used in harsh & noisy industry environments

However, even though the 7000 family is so versatile, there are some applications that cannot be solved. These applications are given as follows:

- High speed applications
- Special hardware requirement applications
- Special software requirement applications
- A combination of special hardware & software applications

Therefore, we developed an I/O expansion bus for the 7188X family to solve all the above applications. The I/O expansion bus can be used to implement various I/O functions such as D/I, D/O, A/D, D/A, Timer/Counter, UART, flash memory, battery backup SRAM, AsicKey & other I/O functions. **Nearly all kinds of I/O functions can be implemented by this bus.**

The I/O expansion bus includes serial & parallel interface. The parallel interface is very similar to ISA bus, so the user can move the old ISA bus design to the I/O expansion bus with very little change.

The I/O pins of serial bus are programmable. They can be programmed as D/I, or D/O. Some pins can be configured to D/I or D/O or timer input or timer output. There are many serial interface devices available today. The features of these serial devices are given as follows:

- Smaller size compared to parallel devices
- Lower cost compared to parallel devices
- Easier to design for isolated applications

The serial interface of the I/O expansion bus make interface to these serial devices very easy.

The combination of serial & parallel interface make the I/O expansion bus very convenient & powerful for various industry applications. There are many design examples given in “I/O Expansion Bus in the 7188X User’s Manual”. All hardware circuit & software driver sources are OPEN for modification. From these examples, the user can make new applications or modify them for their special requirements. The system design steps are given as follows:

- Step 1: list all functions required
- Step 2: for all functions, goto step 3. If all functions are solved → STOP
- Step 3: if this function can be solved by 7000 module → goto step 2
- Step 4: if this function can be solved by 7188X+X??? → goto step 2
- Step 5: user designed special hardware for I/O expansion bus
- Step 6: user writes special software driver for this hardware
- Step 7: combine the special hardware & software as a new module
- Step 8: goto step 2

After the above steps, user can combine the standard 7000 modules & special modules to solve all applications in the same RS-485 network. The system is given as following:

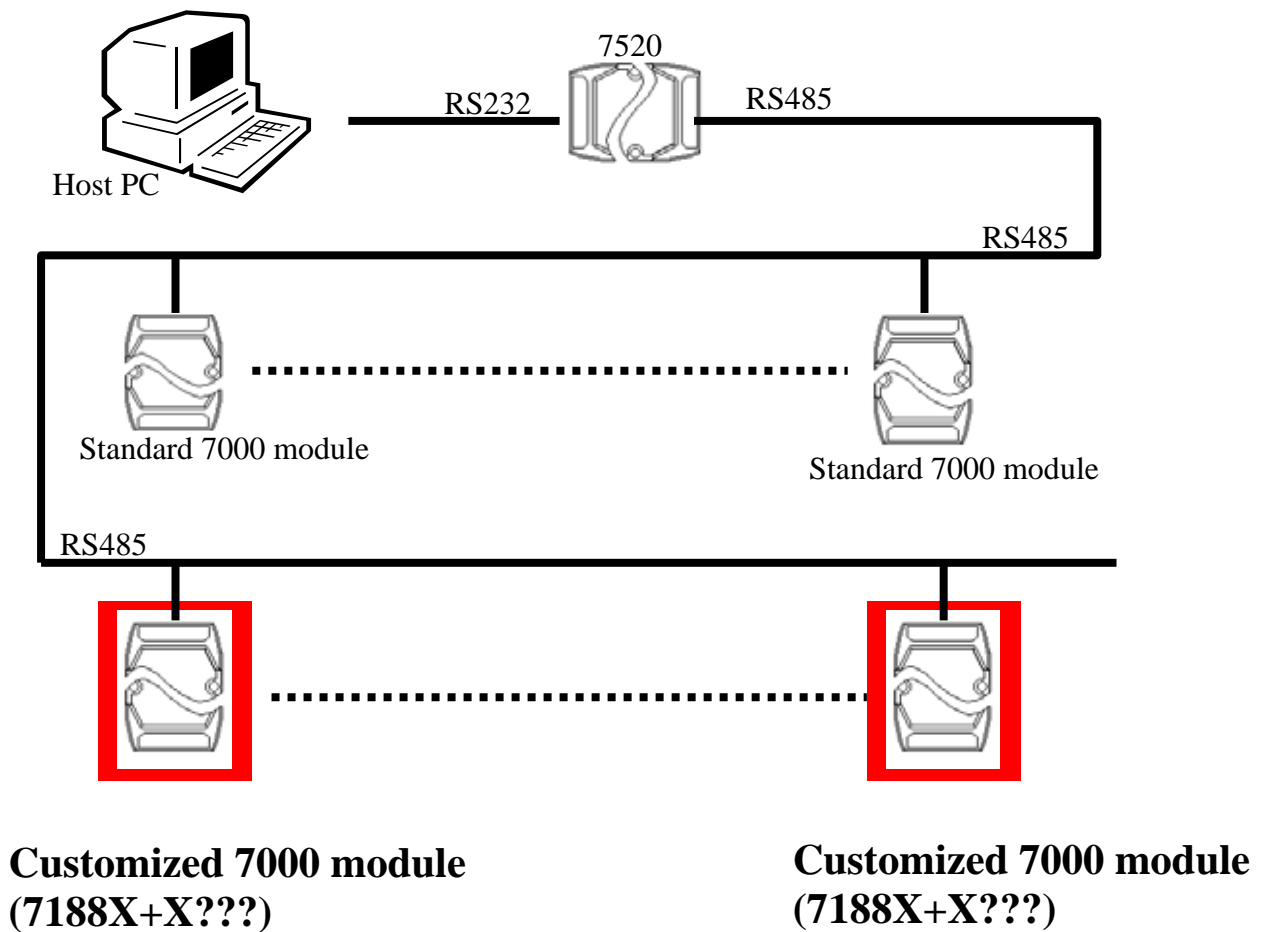

2.11.1 Definition of an I/O Expansion Bus

The I/O expansion bus of the 7188XB series can be divided into 3 groups as follows:

1. Power supply & reset signals: VCC, GND, RESET, /RESET
2. Parallel Bus:
 - System clock: CLOCKA
 - Asynchronous ready control: ARDY
 - Address bus: A0 ~ A6, A7
 - Data bus: D0 ~ D7
 - Interrupt control: INT0, INT1, INT4
 - Chip select & read/write strobe: /CS, /WR, /RD
3. Serial Bus: TO_0, TO_1, TI_0, TI_1, SCLK, DIO9, DIO4, DIO14

Refer to “I/O Expansion Bus for 7188X/7188E User’s Manual” for more information.

2.11.2 Definition

The definition of the I/O expansion bus is given as follows:

JP1 pin definition & description:

No	Name	Description
1	GND	Ground of PCB
2	GND	Ground of PCB
3	CLOCKA	Synchronous clock output of CPU
4	ARDY	Asynchronous ready input (level sensitive, OPEN=ready)
5	INT0	Interrupt request input of channel 0(asynchronous, active high)
6	INT1	Interrupt request input of channel 1(asynchronous, active high)
7	VCC	Power supply of PCB
8	RESET	Power up reset pulse (active high)
9	GND	Ground of PCB
10	/RESET	Power up reset pulse (active low)
11	TO_0	Timer output 0 of CPU (can be used as programmable D/I/O)
12	TO_1	Timer output 1 of CPU (can be used as programmable D/I/O)
13	TI_0	Timer input 0 of CPU (can be used as programmable D/I/O)
14	TI_1	Timer input 1 of CPU (can be used as programmable D/I/O)
15	SCLK	Common serial clock output of 7188 series
16	DIO9	Programmable D/I/O bit
17	DIO4	Programmable D/I/O bit
18	DIO14	Programmable D/I/O bit
19	VCC	Power supply of PCB
20	VCC	Power supply of PCB

- **CLOCKA**: 40M for 7188XB
- **ARDY**: leave this pin OPEN for no wait states applications
- **INT0, INT1**: leave these two pins OPEN for no interrupt applications
- **TO_0, TO_1**: can be used as CPU's timer output or programmable D/I/O
- **TI_0, TI_1**: can be used as CPU's timer input or programmable D/I/O
- **DIO4, DIO9, DIO14**: programmable D/I/O bit
- **SCLK**: the 7188X/7188E series use this signal as a **CLOCK** source to drive all on-board serial devices, so it is always programmed as D/O. Changing this signal to other configurations will cause serious errors. User can use this signal to drive external serial devices without any side effects.

JP2 pin definition & description:

No	Name	Description
1	A0	Address bus
2	D0	Data bus
3	A1	Address bus
4	D1	Data bus
5	A2	Address bus
6	D2	Data bus
7	A3	Address bus
8	D3	Data bus
9	A4	Address bus
10	D4	Data bus
11	A5	Address bus
12	D5	Data bus
13	A6	Address bus
14	D6	Data bus
15	A7 or N/C	This pin is reserved & must be N/C for 7188XC & 7521 series
16	D7	Data bus
17	INT4 or N/C	Interrupt request input of channel 4(asynchronous, active high), this pin is reserved & must be N/C for 7188XC & 7521 series
18	/WR	Write strobe output (synchronous, active low)
19	/CS	Chip select output (synchronous, active low)
20	/RD	Read strobe output (synchronous, active low)

- Address bus (output): A0 ~ A6, A7
- Data Bus (tri-state, bi-direction): D0 to D7
- INT4: leave this pin OPEN for no interrupt applications
- /CS, /RD, /WR: These 3 signals will be synchronous to CLOCKA (in JP1.3) & asynchronous to ARDY (JP1.4)
- The CS\ will be active if program inport/outport from I/O address 0 to 0xff.

Refer to “I/O Expansion Bus in the 7188X/7188E User’s Manual” for more information.

2.11.3 Parallel Bus Timing Diagram

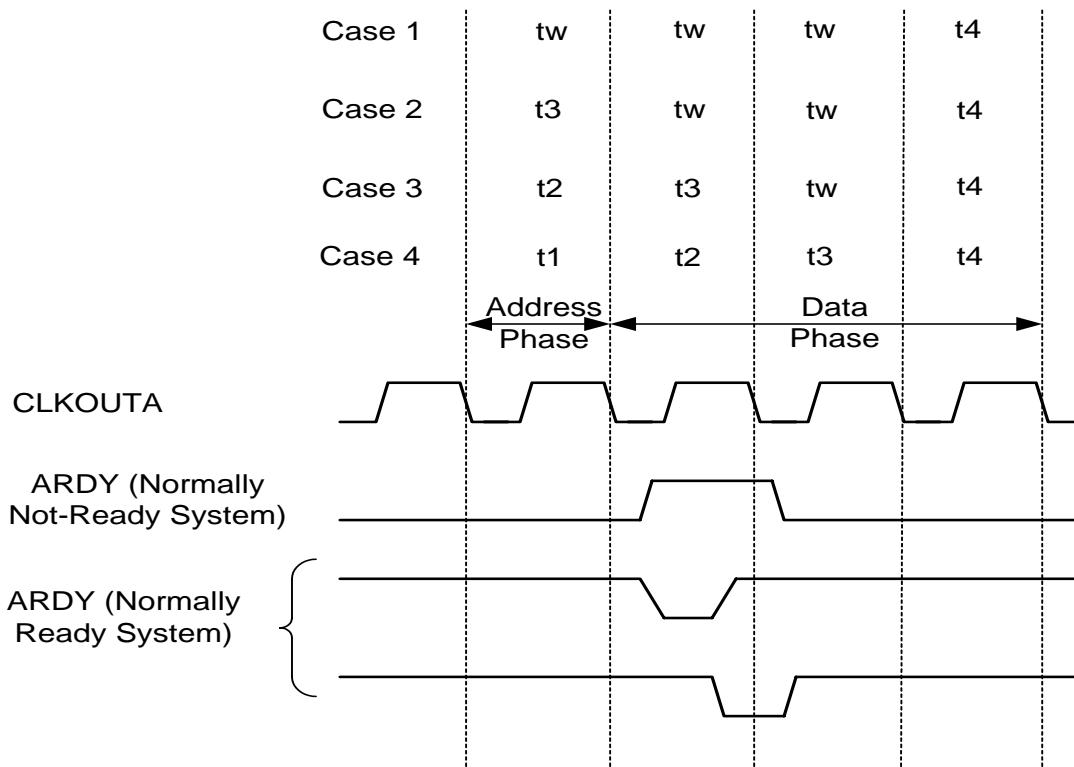
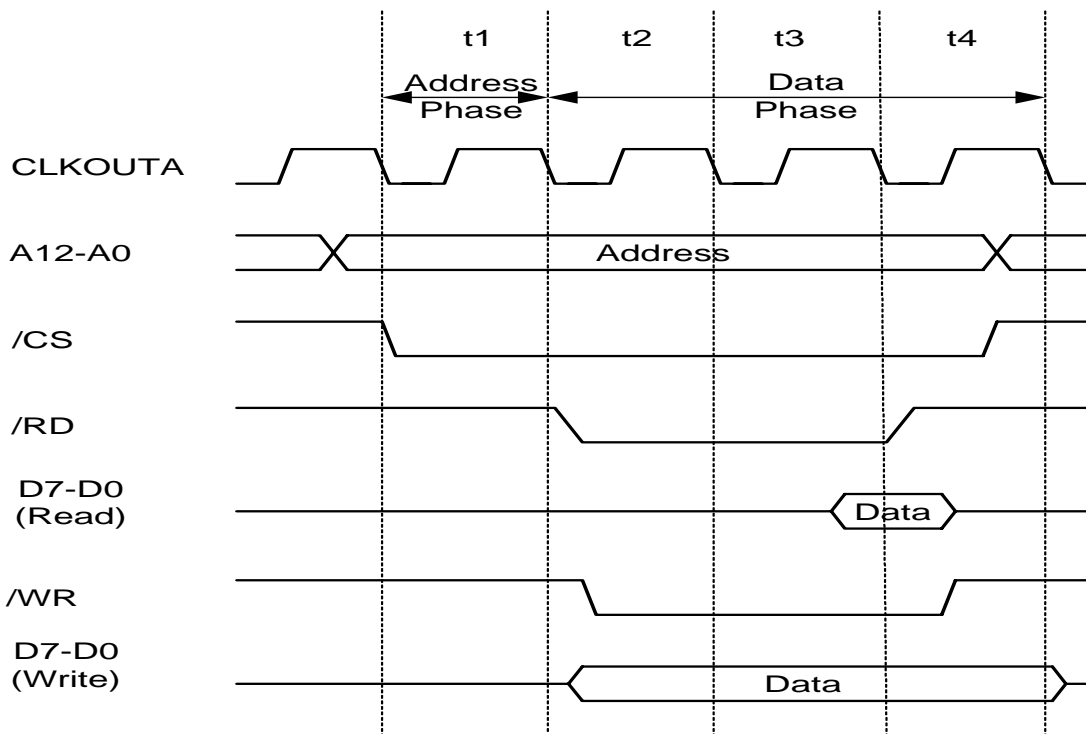

2.11.4 I/O Expansion Boards

I/O expansion board for prototype & testing:

Board	Descriptions	
X000	Prototype Board (Small size)	XA/XC
X001	Prototype Board (Large size)	XA/XC
X002	Prototype Board	XA/XB/XC/EX
X003	Self-test board for 7188XC	XC
X004	Self-test board for 7188XB/EX	XB/EX
X005	Prototype Board (small size)	XB/EX
X006	Prototype Board (Large size)	XB/EX
More.....		

I/O expansion board for D/I, D/O, D/I/O, or Timer/Counter :

Board	Descriptions	
X100	8 channels of D/I, 3.5V~30V	XC
X101	8 channels of D/O, TTL(64mA)	XC
X102	2 channels of relay output	XC
X103	7 channels of isolated D/I(3.5V ~ 30V)	XC
X104	8 channels of D/I/O(single channel programmable)	XC
X105	8 channels of D/I/O(8-channel programmable)	XC
X106	2*D/O or 3*D/I	XC
X107	6 channels of D/I + 7 channels of D/O	XB/XC
X400	3 channels 16-bit Timer/ Counter expansion Board	XC
More.....		

I/O expansion board for A/D, D/A, DI, DO:

X200	1 channel of 12-bit A/D(0~2.5V)	XC
X201	4 channels of 12-bit A/D(0~20mA)	XC
X202	7 channels of 12-bit A/D(0~20mA)	XB/EX
X204	2 channels of 12-bit A/D(+/- 1V)	XC
X300	2 channels of 12-bit D/A(0~4.095V)	XC
X301	1 channel of 12-bit A/D(0~2.5V) and 1 channel of 12-bit D/A(0~4.095V)	XC
X302	1 channel of 12-bit A/D(+/- 5V) and 1 channel of 12-bit D/A(+/- 5V)	XC

More.....

I/O Expansion Board for A/D, D/A, D/I, D/O:

X203	2 channels of 12-bit A/D(0~20mA)	XB/EX
X303	1 channel of 12-bit A/D(+/- 5V) and 1 channel of 12-bit D/A(+/- 5V)	XB/EX
X304	3 channels of 12-bit A/D(+/- 5V) and 1 channel of 12-bit D/A(+/- 5V)	XB/EX
X305	7 channels of 12-bit A/D(+/- 5V) and 1 channel of 12-bit D/A(+/- 5V)	XB/EX

More.....

I/O Expansion Board for RS-232/422, D/I, D/O:

X500	1 channel of RS-232, modem control, 115.2K max.	XC
X501	1 channel of 4-wire RS-232 (RTS, CTS, TXD, RXD), 115.2K max	XC
X502	1 channel of 4-wire RS-232 (RTS, CTS, TXD, RXD) & 1 channel of 2-wire RS-232 (TXD, RXD) ,115.2K max	XC
X503	1 channel of 4-wire RS-232 (RTS, CTS, TXD, RXD), 115.2K max	XB/EX
X504	1 channel of 4-wire RS-232 (RTS, CTS, TXD, RXD) & 1 channel of 8-wire RS-232 (RI,DCD,DTR,DSR,CTS,RTS, CTS, TXD, RXD) ,115.2K max	XB/EX
X505	1 channel of 4-wire RS-232 (RTS, CTS, TXD, RXD), 115.2K max	XB/EX
X506	1 channel of 2-wire RS-232 (TXD, RXD), 115.2K max	XB/EX
X507	1 channel of 4-wire RS-422/485 and DI/O (RXD3+, RXD3-, TXD3+, RXD3-) , 115.2K max	XB/EX
X508	1 channel of 4-wire RS-232 and DI/O (RTX,CTX,TXD, RXD) , 115.2K max	XB/EX
X509	1 channel of 2-wire RS-232 and DI/O (TXD, RXD), 115.2K max	XB/EX
X510	1 channel of 2-wire RS-232/485 and DI/O , RS-232(TXD, RXD) , RS-485(D+,D-),115.2K max	XB/EX

More.....

I/O Expansion Board for storage devices:

X600/2	2M bytes NAND Flash	XA/XB/XC/EX
X600	4M bytes NAND Flash	XA/XB/XC/EX
X601	8M bytes NAND Flash	XA/XB/XC/EX
X602	16M bytes NAND Flash	XA/XB/XC/EX
X603	32M bytes NAND Flash	XA/XB/XC/EX
X607	128K battery backup SRAM	XA/XB/XC/EX
X608	512K battery backup SRAM	XA/XB/XC/EX
More.....		

Refer to “I/O Expansion Bus in the 7188X/7188E User’s Manual” for more information.

3. Applications

3.1 Embedded Controllers

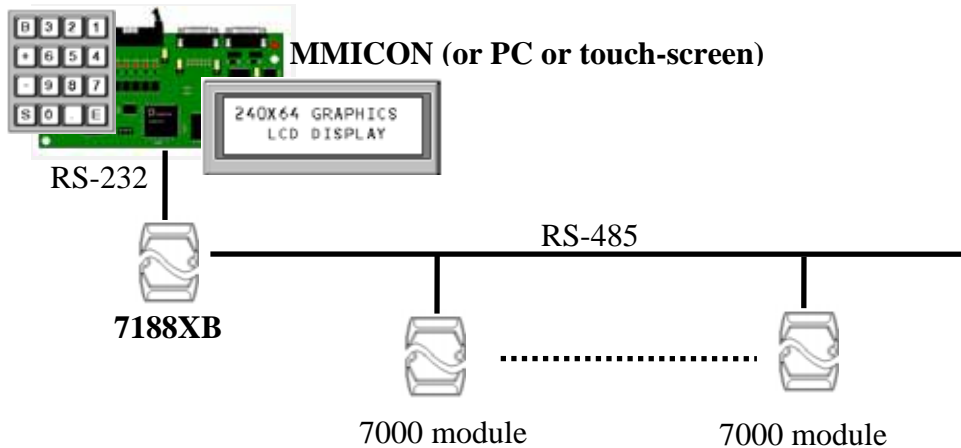

Applications:

- **4500 replacement & enhancement (not compatible)**
- **PC-Based controller replacement**
- **PLC replacement**
- **Special controller replacement**

The 7188XB series can be use as embedded controller for general applications. Therefore it can be used to replace PC, PLC or special controllers.

Programming Tool	TC/MSC/BC
Debug Tool	Via standard input/output (keyboard & monitor of PC)
Man Machine Interface	<ul style="list-style-type: none"> ● MMICON ● Keyboard & monitor of PC ● Touch Screen (RS-232 or RS-485 interface)
Program	Stored in Flash ROM
Input/Output	<ul style="list-style-type: none"> ● Onboard D/I or D/O ● From I/O Expansion Bus ● 7000 series modules, can directly control 256 modules = thousands of I/O points

3.2 Local Real Time Controller

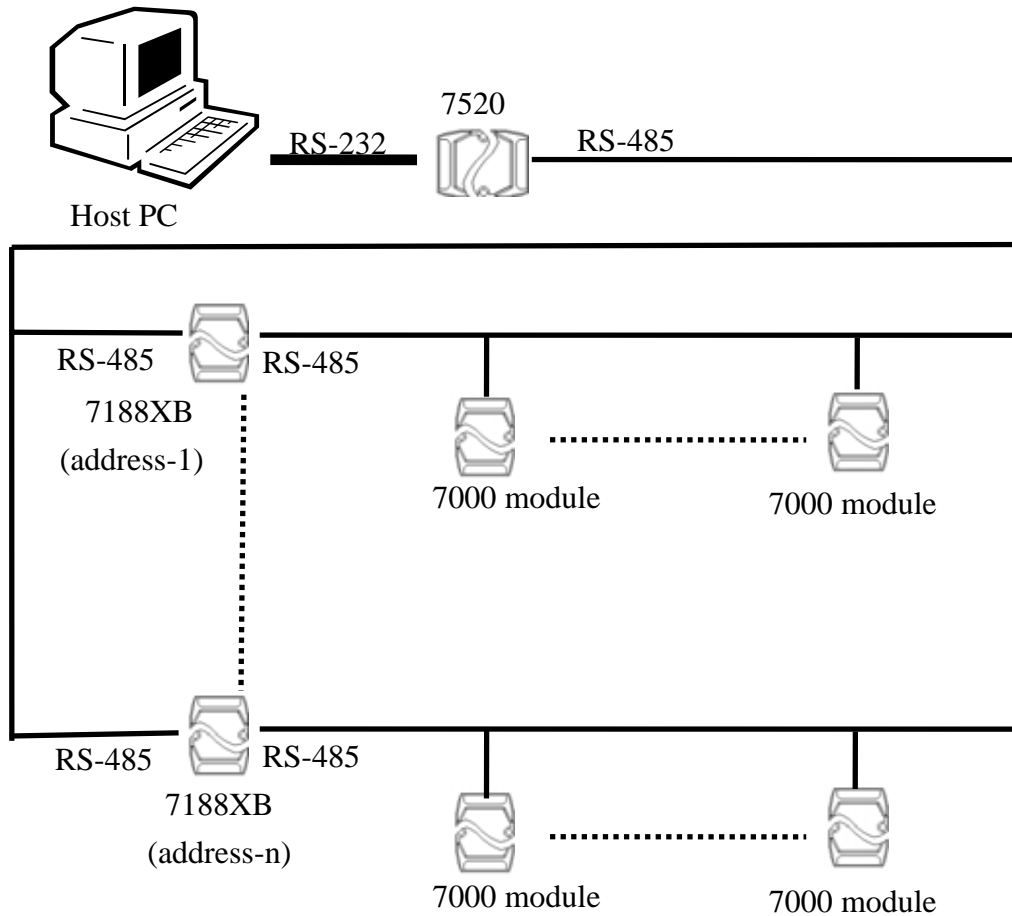

The 7000 series modules are slave devices; the control programs are implemented in host PC. The working steps are given as follows:

1. PC sends out commands to 7000 modules for input data.
2. PC analyzes this input data & generates some output data
3. PC send out commands to 7000 modules for output data

If there are hundreds of 7000 modules, the PC will take a long time to analyze & control these modules.

The control program can be implemented in a local 7188XB. The PC only has to send control arguments to the 7188XB, the 7188XB will control the local 7000 modules based on these control arguments. In this way, the PC can handle thousands of 7000 modules with the 7188XB.

Some control functions are **timing critical**. The local 7188XB can handle these functions without the PC in real time.

3.3 Remote Local Controller

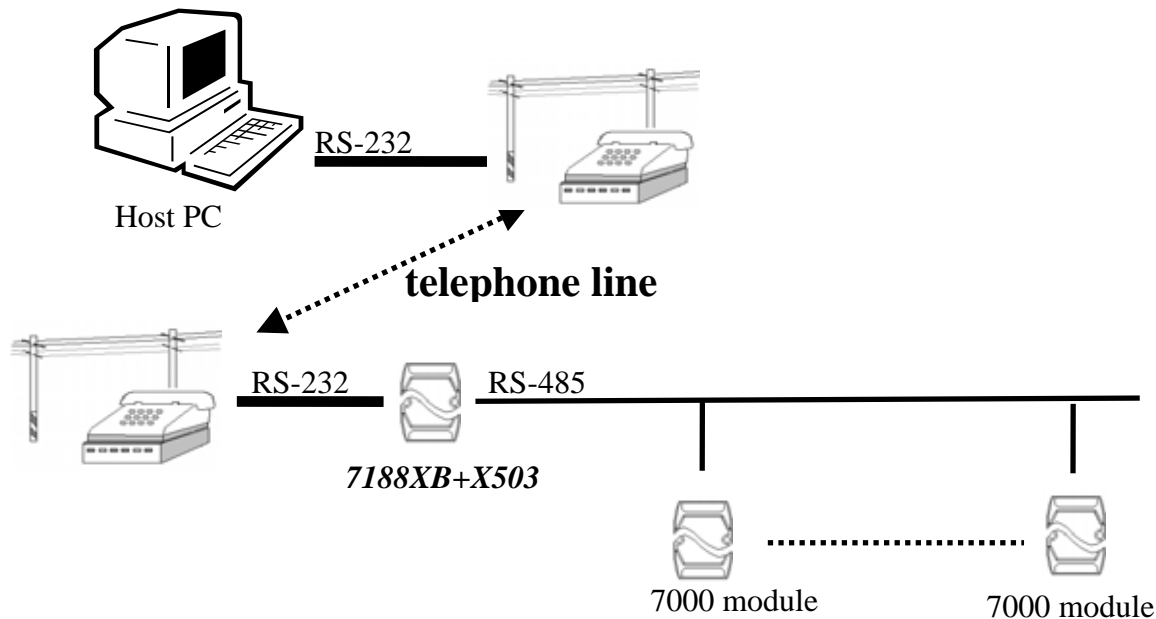

The control program is implemented in a local 7188XB. The 7188XB will directly control the 7000 modules based on these control arguments.

The PC can access the remote 7188XB for the following items:

- Query & record the remote system status
- Download the control arguments to remote 7188XB

The remote 7188XB can communicate to the PC for the following items:

- Emergency events call back
- Remote system status send back

Note: The 7188XB must add a X503 to control the modem.

3.4 I/O Expansion of PLC applications

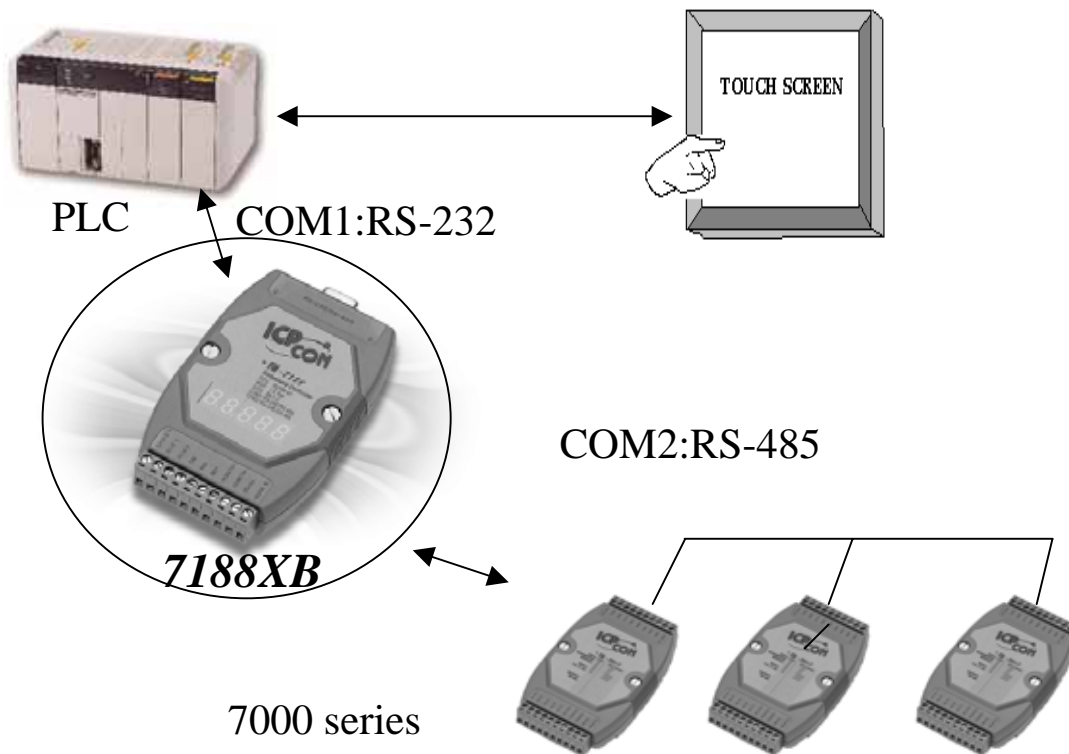

There is a Man Machine Interface in most PLCs. This interface is originally designed for MMI applications. The 7188XB can use this interface to build a bridge between PLC & 7000 modules.

The 7188XB can directly read/write the internal memory of the PLC. Therefore the **PLC can access the 7000 input modules** as follows:

1. The 7188XB sends commands to the 7000 input modules
2. The 7188XB writes this data to the PLC's internal memory
3. The PLC accesses this data from the internal memory

The **PLC can control the 7000 output modules** as follows:

1. The PLC writes data to its internal memory
2. The 7188XB reads this output data from the PLC's memory
3. The 7188XB sends commands to the 7000 output modules

In this way, the input data of the 7000 modules can be shown on the touch screen. Also, the user can control the output of the 7000 modules from the touch screen.

3.5 Radio Modem Applications

Configuration 3
Point to multi-point application

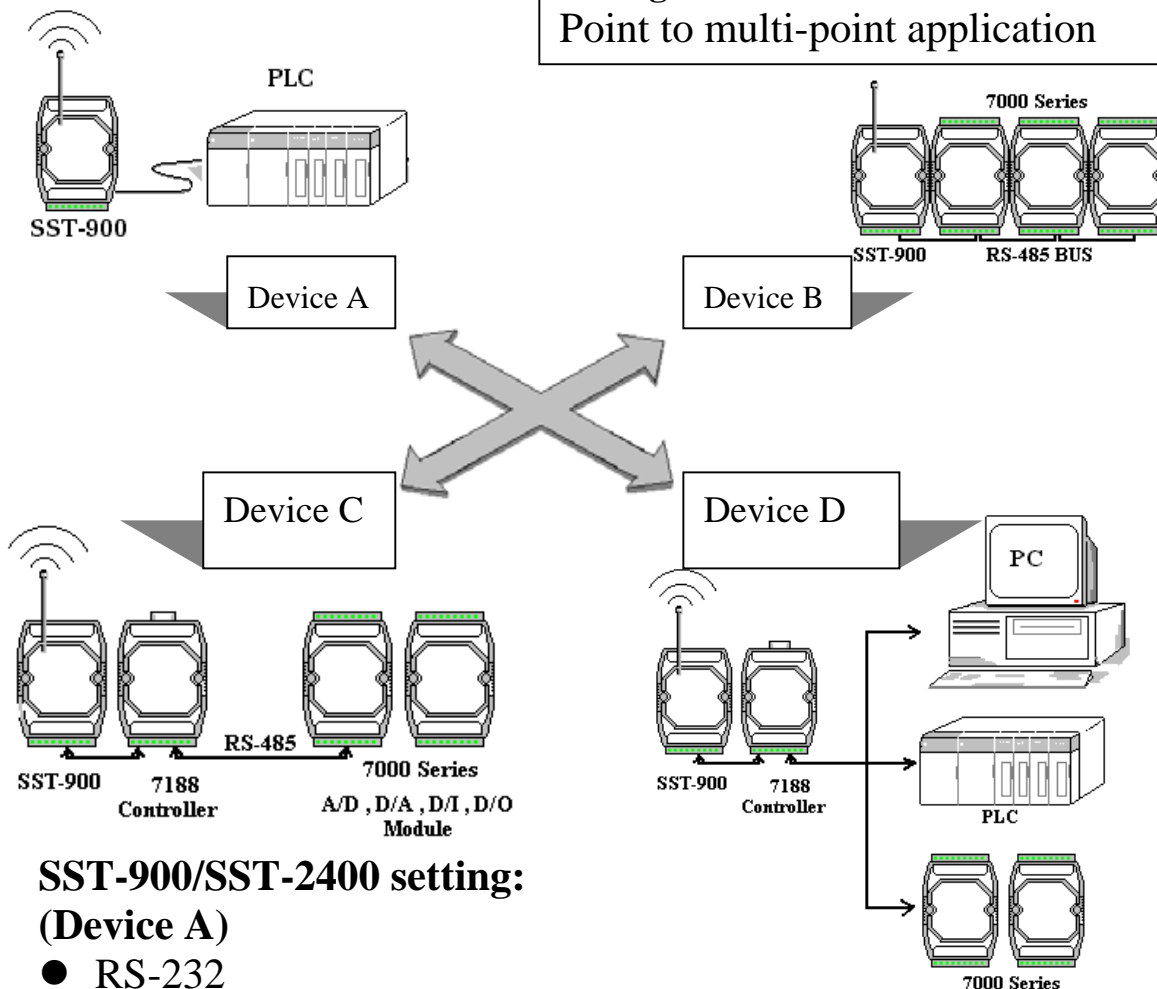

SST-900/SST-2400 setting: (Device A)

- RS-232
- Half-duplex mode
- Synchronous way
- Slave state
- Baud rate=9600
- Channel=3
- Frequency=915.968MHz

The 7188XB series is an embedded controller. Because the 7188XB series is programmable, **it can be used as a bridge between the SST-900 & external devices.** These devices can be PLC, controller or 7000 modules.

SST-900/SST-2400 setting: (Device B/C/D)

- RS-485 or RS-232
- Half-duplex mode
- Synchronous way
- Slave state
- Baud rate=9600
- Channel=3
- Frequency=915.968MHz

3.6 Using 4 COM port Application-1

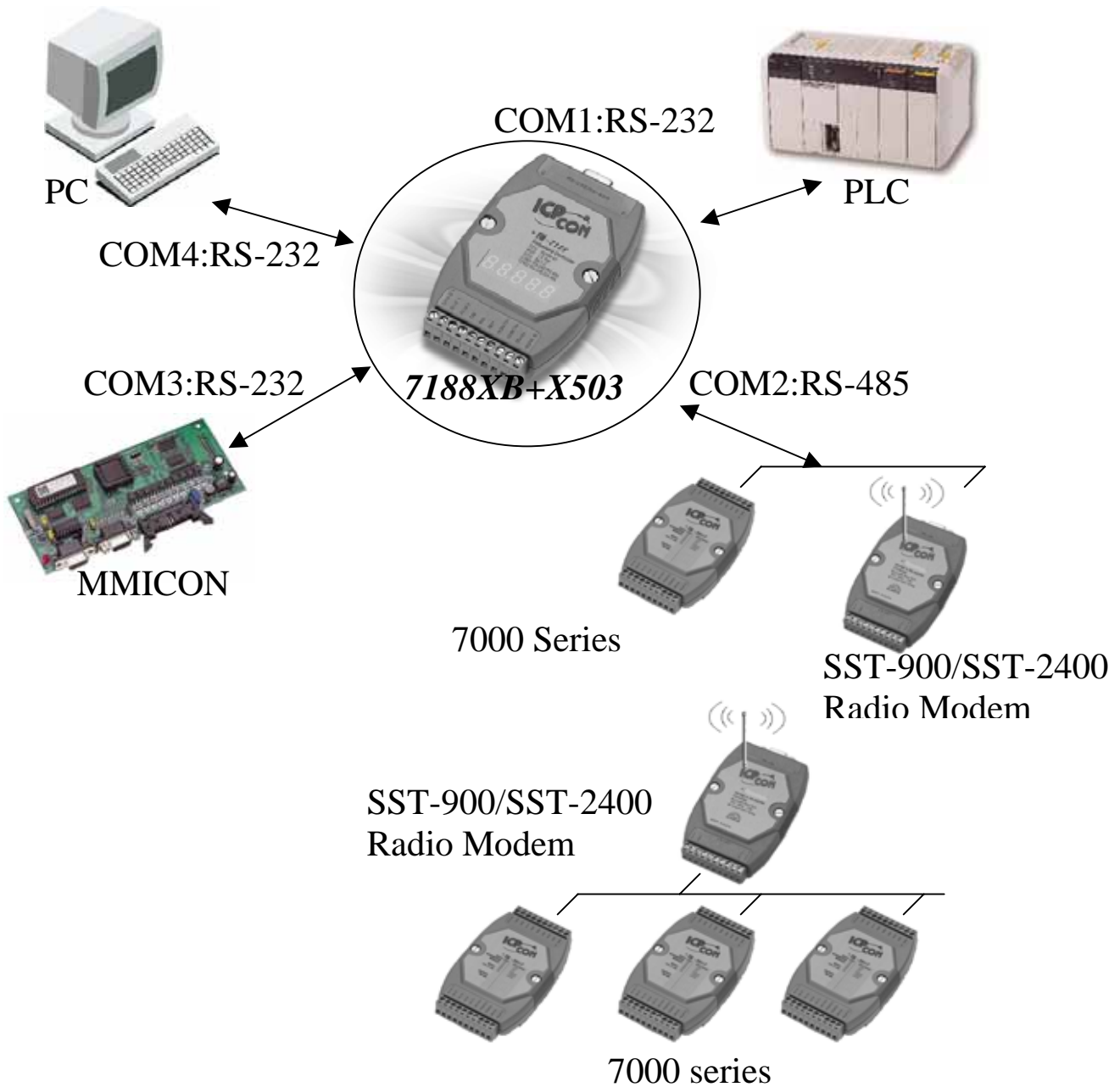

- COM1: PLC can access the I/O states of 7000 modules
- COM2: Directly controls the 7000 input/output modules
- COM3: MMICON is used as the local MMI
- COM4: PC is used to monitor & record the system data.

Note: The 7188XB must add a X503 for 4-COM port applications.

3.7 Using 4 COM port Application-2

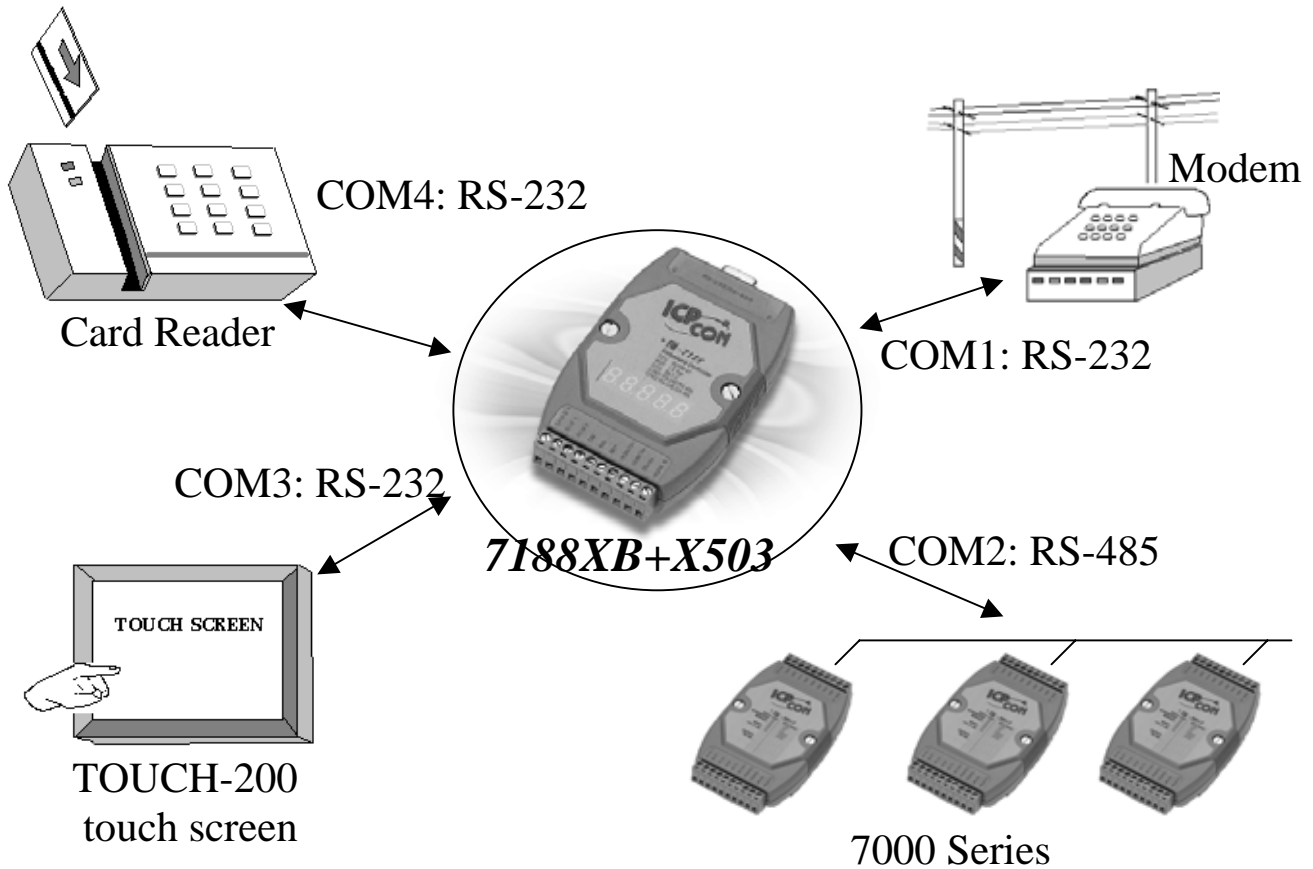

COM1: link to remote host PC

COM2: Directly controls the 7000 input/output modules

COM3: TOUCH-200 is used as the local MMI

COM4: Card reader is used as standard input device.

Note: This application is for the 7188XB+X503