

LEC-BT

SMARC® Full Size Module with Intel® Atom™ Processor E3800 Series System-on-Chip

Features

- Single, dual or quad-core Intel® Atom™ Processor E3800 Series System-on-Chip
- Up to 8 GB DDR3L at 1066/1333 MHz (ECC)
- HDMI and LVDS, onboard eMMC
- GbE, camera interface
- 1x SATA 3Gb/s, 1x USB 3.0, 3x USB 2.0,
- max. 12x GPIO
- Extreme Rugged™ operating temperature: -40°C to 85°C

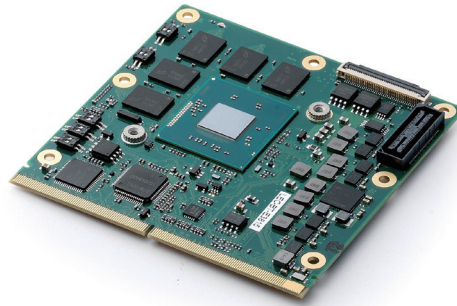

Specifications

Core System

CPU	Intel® Atom™ E3800 Series, single, dual or quad-core SoC with integrated graphics Atom™ E3845 (4C/1333), 1.91 GHz, Gfx 542/792 MHz (Turbo), 10 W TDP Atom™ E3826 (2C/1066), 1.46 GHz, Gfx 533/667 MHz (Turbo), 7 W TDP Atom™ E3815 (1C/1066), 1.46 GHz, Gfx 400/-MHz (No Turbo), 5 W TDP Atom™ E3805 (2C/1066), 1.33 GHz (No GFX) 3W TDP
Memory	Up to 8 GB DDR3L at 1066/1333 MHz, memory down with ECC
Alignment	AMI UEFI with CMOS backup in 8 MB SPI BIOS, Fast Boot support
Cache	512 kB to 2 MB L2 cache
SEMA Board Controller	Supports: Voltage/Current monitoring, Power Sequencing, Logistics and Forensic Information, Flat Panel Control, I²C Bus Control, GPIO Control, User Flash, Failsafe BIOS (dual BIOS), Watchdog Timer and Fan Control

Audio

Chipset	Intel® HD Audio integrated in SOC
Ports	I²S and HDA for audio codec on carrier

Ethernet

Intel® MAC/PHY Interface	1x Intel® i210IT Ethernet controller 10/100/1000 GbE
--------------------------	---

Video

GPU Feature Support	7th generation Intel® graphics core architecture with four execution units, supports two independent displays 2D and 3D graphics hardware acceleration Support for DirectX 11.1, OGL ES 2.0, OGL 3.2 Video decode HW acceleration for H.264, MPEG2, VC1, VP8 formats Video encode HW acceleration for H.264, MPEG2 formats
LVDS	Single channel 18/24-bit LVDS from DDIO
HDMI	HDMI 1.4a from DDI1

I/O Interfaces

PCIe	3x PCIe x1 Gen2
USB	1x USB 3.0 + 3x USB 2.0
SATA	1x SATA 3 Gb/s
eMMC	Soldered, bootable eMMC flash storage from 4 to 64 GB (optional)
SDIO	1x SDIO (4-bit)
GPIO	12x GPIO, 5x used for camera, 7x available
Camera	CSI 4L/1L
Serial	2x SPI, 2x I2C, 1x I2S, Power Management, 2x UART

Power

Standard Input	3.0 V ~ 5.25 V DC ±5%
Power States	Supports C0-C6, S0, S3, S4, S5

Mechanical and Environmental

Form Factor	SMARC Specifications v1.1
Dimensions	SMARC full size module, 82 mm x 80 mm
Operating Temperature	Standard: 0°C to +60°C Extreme Rugged: -40°C to +85°C
Humidity	5-90% RH operating, non-condensing 5-95% RH storage (and operating with conformal coating)
HALT	Thermal Stress, Vibration Stress, Thermal Shock and Combined Test

Operating Systems

Standard Support	Linux, VxWorks, Windows 7/8, Windows Embedded, Compact 7
Extended Support (BSP)	QNX, Android

Functional Diagram

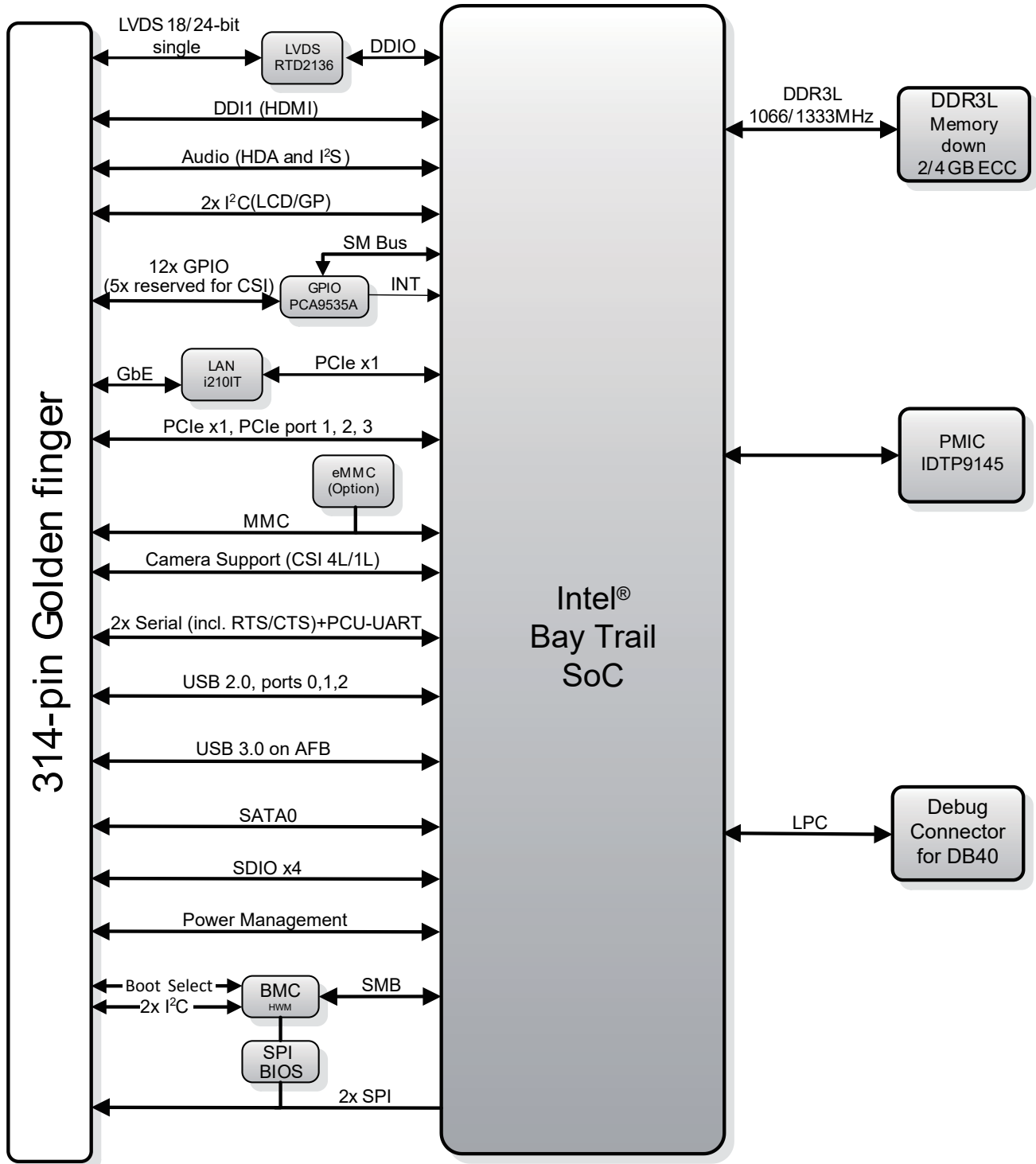

Intelligent Middleware



Middleware Name	SEMA®
Description	Local management, control of embedded computer systems Extended EAPI for monitoring, controlling and analytics applications Multiple OS support and across platforms (x86, ARM)

Intelligent IOT Platform



Platform Name	SEMA Cloud®
Description	Application ready comprehensive industrial grade IoT Platform Connecting Devices to a Cloud Platform and to Web Applications Remote monitoring and controlling managing of connected devices Enabling integration of operational device data into business processes Cloud based Platform as a Service (PaaS)

Ordering Information

- **LEC-BT4-4G-8G-ER**
SMARC Full Size Module with Intel® Atom™ E3845, quad core, 4 GB DDR3L, 8 GB eMMC, Extreme Rugged™ operating temperature: -40°C to +85°C
- **LEC-BT2-2G-8G-ER**
SMARC Full Size Module with Intel® Atom™ E3826, dual core, 2 GB DDR3L, 8 GB eMMC, Extreme Rugged™ operating temperature: -40°C to +85°C
- **LEC-BT1-2G-8G-ER**
SMARC Full Size Module with Intel® Atom™ E3815, single core, 2 GB DDR3L, 8 GB eMMC, Extreme Rugged™ operating temperature: -40°C to +85°C
- **LEC-BT-HS**
Heatspreader for LEC-BTS

*other configurations by request