

Cervoz Industrial Embedded Module

mSATA

Momentum Series (MLC)

M305 Family

Product Datasheet



Date: 2016.09.02

Revision: 3.0

File: Cervoz_Industrial_Embedded_Module_mSATA_M305_Datasheet_Rev3.0



Revision History

Date	Revision	Description
2016.06.21	1.0	First Released
2016.08.02	2.0	Wide Temperature Solution Information Added
2016.09.02	3.0	256GB Solution Information Added



Table of Contents

1. Product Overview	4
1.1 Introduction	4
1.2 Application Fields	4
1.3 Features	4
1.4 Product Appearance & Models	5
2. Product Specifications	6
2.1 General Specifications	6
2.2 Performance	7
2.3 Drive Capacity	7
2.4 Electronic Specifications	8
2.4.1 Block Diagram	8
2.4.2 Pin Assignment	9
2.5 Environmental Specifications	10
2.6 Mechanical Specifications	10
3. Supported Command	11
3.1 List of Command Sets	11~12
3.2 Identify Device	13~15
3.3 Identify Device SMART Feature Set	16
3.4 SMART Data Feature	16~17
3.5 SMART Attributes	18
4. Part No. Decoder	19
4.1 Part No. Decoder	19~20

1. Product Overview

1.1 Introduction

Cervoz Industrial mSATA Embedded Module M305 family is a Solid State Flash Disk product that is in compliance with the mSATA and SATA III standards. mSATA M305 family fits in any mSATA sockets in a PC or motherboard; it can be used for both booting and storage purposes.

M305 family uses superior quality preselected multi-level cell (MLC) NAND flash memory from the industry leading manufacturer Micron. This product includes both standard temperature range and wide temperature range options with various capacities to choose from.

M305 family offers outstanding performance and reliability; the product family is a perfect solution for price sensitive semi-industrial and general industrial applications.

1.2 Application Fields

- Industrial PC and Thin Client
- Ticketing, Examining and Testing Machine
- Military, Health and Automatic Equipment
- Server, Cloud Computer

1.3 Features

- Compliant with SATA III 6.0Gb/s (backward compatible to 1.5Gb/s and 3Gb/s)
- MLC NAND flash memory
- Capacity: 16GB ~ 256GB
- Operating as boot disk
- Low power consumption
- Shock resistance and anti-vibration
- Static and dynamic wear leveling
- Bad block management
- S.M.A.R.T. & TRIM command
- Fully compatible with Windows XP, Windows 7, Windows 8, Windows 10, Mac OS, and Linux
- RoHS compliant

1.4 Product Appearance & Models

Cervoz Industrial mSATA Module M305



M305 Family Standard Temp. (0°C ~ 70°C) Model No.	M305 Family Wide Temp. (-40°C ~ 85°C) Model No.	Capacity
CIE-MSM305MJB016GS	N/A	16GB
CIE-MSM305MKB032GS	CIE-MSM305MKB032GW	32GB
CIE-MSM305MKB064GS	CIE-MSM305MKB064GW	64GB
CIE-MSM305MKB128GS	CIE-MSM305MKB128GW	128GB
CIE-MSM305MLB256GS	N/A	256GB

Please Note:

Since certain storage capacity has to be reserved for firmware and controller management purposes; the physical capacity of the SATA flash module will be approximately 92.5% of the indicated capacity. If you need to install an image that has the exact (or close to) the indicated size of the flash module, please choose your flash module with a greater capacity.

2. Product Specifications

2.1 General Specifications

Form Factor	mSATA
Interface	SATA III 6.0Gb/s (backward compatible to 3.0Gb/s, 1.5Gb/s)
Connector	mSATA
NAND Flash Type	MLC
Capacity	Standard Temp. : 16GB/32GB/64GB/128GB/256GB
	Wide Temp. : 32GB/64GB/128GB
Sequential Read	up to 500MB/s
Sequential Write	up to 280MB/s
ECC Scheme	up to 66bits / 1K Byte
MTBF	2,000,000 hours
Terabyte Written (TBW)	16GB : 15.6
	32GB : 31
	64GB : 63
	128GB : 125
	256GB : 250
Low Power Management	DEVSLP mode
	DIPM/HIPM mode
Supply Voltage	+3.3V DC \pm 5%
Power Consumption	Active mode: < 940mW
	Idle mode: < 100mW
	DEVSLP mode: < 5mW
Dimension (LxWxH)	50.95*30.00*3.90mm
Weight	6.5 \pm 1g

2.2 Performance

The performance was measured with below PC configuration:

- Platform: GIGABYTE GA-Z97MX-Gaming5 (Intel Z97)
- RAM: Cervoz CIR-S3DUSI1302G(DDR3 2G 1333MHz)
- Operation Systems: Windows 7 SP1
- Testing Utility: Crystal Disk Mark v3.0 x64
- SATAIII port (6.0 Gb/s) performance

Capacity	16GB	32GB	64GB	128GB	256GB
Sequential Read (max.)	125MB/s	255MB/s	505MB/s	530MB/s	500MB/s
Sequential Write (max.)	20MB/s	40MB/s	80MB/s	160MB/s	280MB/s
4KB Random Read (QD32)	22MB/s	43MB/s	85MB/s	120MB/s	120MB/s
4KB Random Write (QD32)	17MB/s	40MB/s	80MB/s	150MB/s	220MB/s

2.3 Drive Capacity

Capacity	Cylinders	Heads	Sectors	Max LBA
16GB	16,383	16	63	31,277,232
32GB	16,383	16	63	62,533,296
64GB	16,383	16	63	125,045,424
128GB	16,383	16	63	250,069,680
256GB	16,383	16	63	500,118,192



2.4 Electronic Specifications

2.4.1 Block Diagram

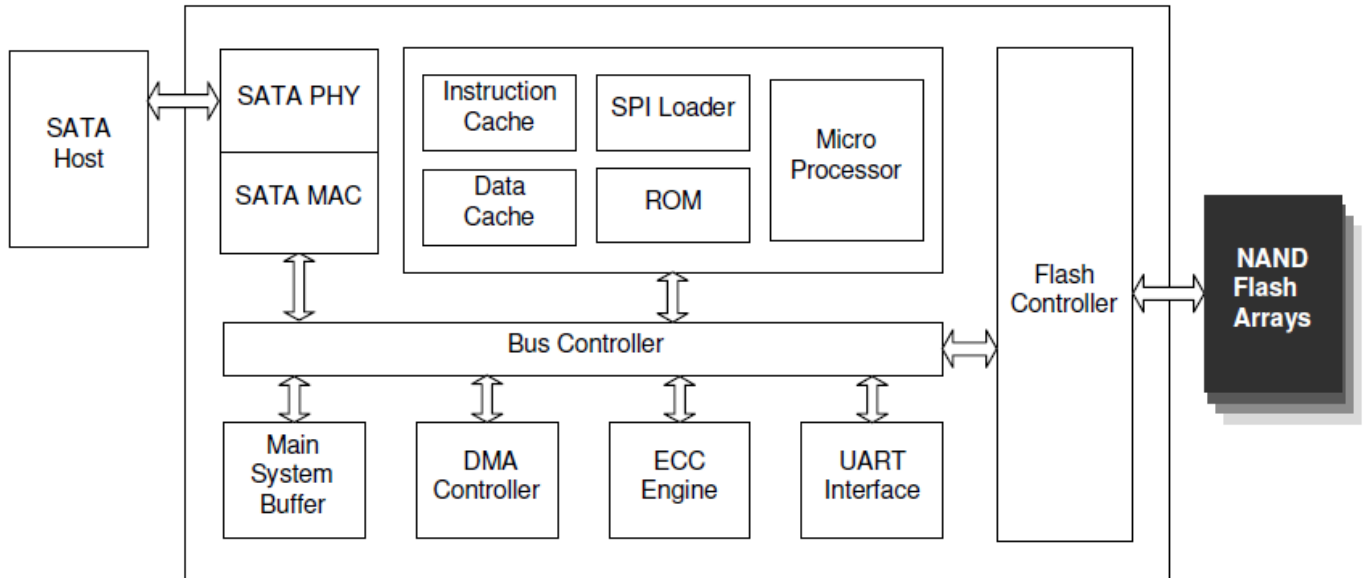

2.4.2 Pin Assignment

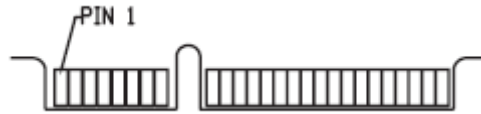

Pin #	Pin Description	Signal Name	Pin #	Pin Description	Signal Name
1	NC	NA	27	System ground	GND
2	DC 3.3V power in	+3.3V	28	Reserved pin	Reserved
3	NC	NA	29	System ground	GND
4	System ground	GND	30	NC	NA
5	NC	NA	31	SATA Differential RX-	SATA_RX-
6	Reserved pin	Reserved	32	NC	NA
7	NC	NA	33	SATA Differential RX+	SATA_RX+
8	NC	NA	34	System ground	GND
9	System ground	GND	35	System ground	GND
10	NC	NA	36	Reserved pin	Reserved
11	NC	NA	37	System ground	GND
12	NC	NA	38	Reserved pin	Reserved
13	NC	NA	39	DC 3.3V power in	+3.3V
14	NC	NA	40	System ground	GND
15	System ground	GND	41	DC 3.3V power in	+3.3V
16	NC	NA	42	NC	NA
17	NC	NA	43	NC	NA
18	System ground	GND	44	Device sleep signal in	DEVSLP
19	Reserved pin	Reserved	45	NC	NA
20	Reserved pin	Reserved	46	NC	NA
21	System ground	GND	47	NC	NA
22	NC	NA	48	Reserved pin	Reserved
23	SATA Differential TX+	SATA_TX+	49	Data access signal out	DAS
24	DC 3.3V power in	+3.3V	50	System ground	GND
25	SATA Differential TX-	SATA_TX-	51	System ground	GND
26	System ground	GND	52	DC 3.3V power in	+3.3V

2.5 Environmental Specifications

Type		Value
Temperature	Standard Temperature Operating:	0°C~70°C
	Standard Temperature Storage:	-40°C~85°C
	Wide Temperature Operating:	-40°C~85°C
	Wide Temperature Storage:	-50°C~95°C
Humidity	Operating & Storage	5~95%, Non-Condensing
Vibration	Non-Operating	20G, 10Hz~2000Hz
Shock	Non-Operating	1500G, 0.5ms

2.6 Mechanical Specifications

Type	Value
Form Factor	mSATA
Length	50.95mm +0 / -0.30mm
Width	30.00mm +0 / -0.30mm
Thickness	3.90mm ± 0.30mm

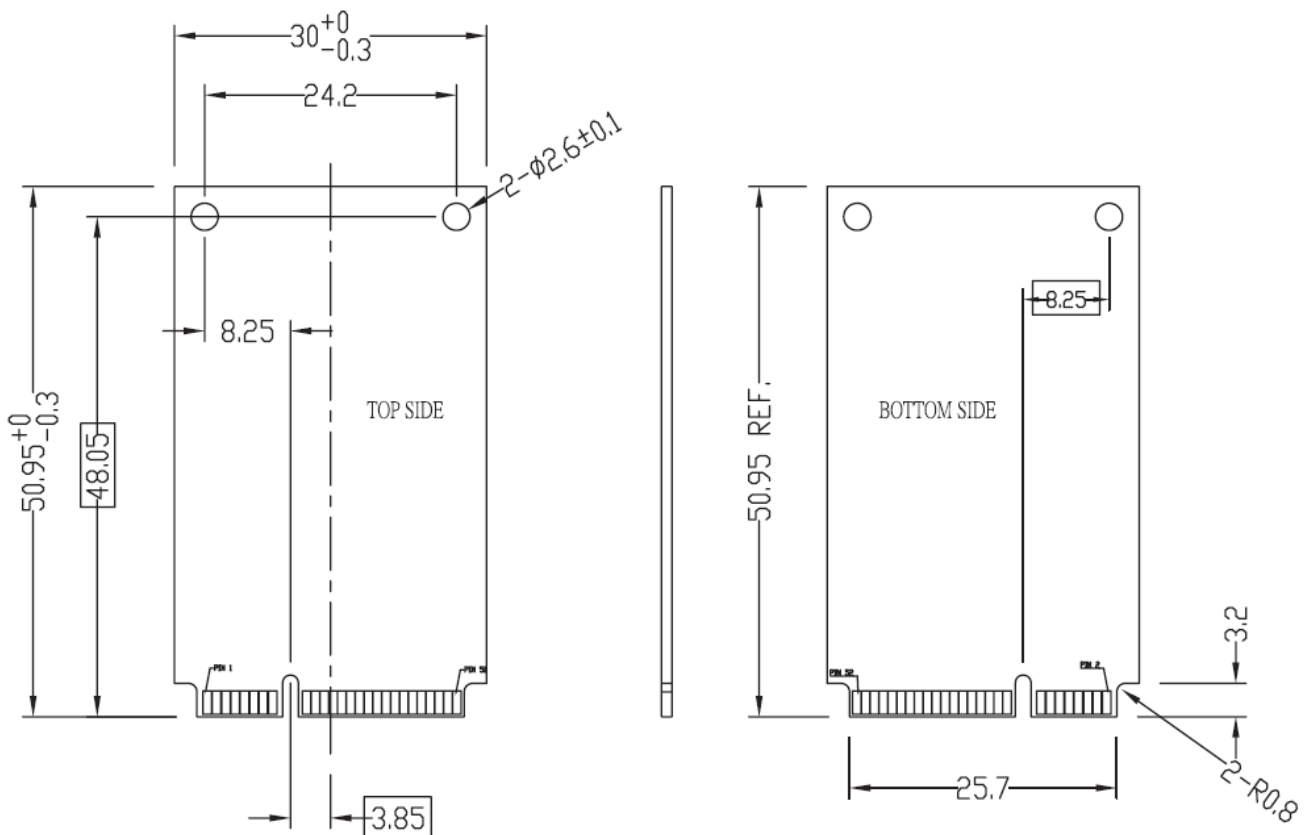

3. Supported Command

3.1 List of Command Sets

Command	Code	Protocol
General Feature Set		
Execute Device Diagnostic	90h	Execute device diagnostic
Flush Cache	E7h	Non-data
Identify Device	ECh	PIO data-in
Initialize Drive Parameters	91h	Non-data
NOP	00h	Non-data
Read Buffer	E4h	PIO data-in
Read DMA	C8h	DMA
Read Log Ext	2Fh	PIO data-in
Read Multiple	C4h	PIO data-in
Read Sector(s)	20h	PIO data-in
Read Verify Sector(s)	40h or 41h	Non-data
Set Feature	EFh	Non-data
Set Multiple Mode	C6h	Non-data
Write Buffer	E8h	PIO data-out
Write DMA	CAh	DMA
Write Multiple	C5h	PIO data-out
Write Sector(s)	30h	PIO data-out
Power Management Feature Set		
Check Power Mode	E5h or 98h	Non-data
Idle	E3h or 97h	Non-data
Idle Immediate	E1h or 95h	Non-data
Sleep	E6h or 99h	Non-data
Standby	E2h or 96h	Non-data
Standby Immediate	E0h or 94h	Non-data
Security Mode Feature Set		
Security Set Password	F1h	PIO data-out
Security Unlock	F2h	PIO data-out
Security Erase Prepare	F3h	Non-data
Security Erase Unit	F4h	PIO data-out
Security Freeze Lock	F5h	Non-data
Security Disable Password	F6h	PIO data-out

Command	Code	Protocol
SMART Feature Set		
SMART Disable Operations	B0h	Non-data
SMART Enable/Disable Autosave	B0h	Non-data
SMART Enable Operations	B0h	Non-data
SMART Execute OFF-LINE Immediate	B0h	Non-data
SMART Read Log	B0h	PIO data-in
SMART Read Data	B0h	PIO data-in
SMART Read Threshold	B0h	PIO data-in
SMART Return Status	B0h	Non-data
SMART Save Attribute Values	B0h	Non-data
SMART Write Log	B0h	PIO data-out
Host Protected Area Feature Set		
Read Native Max Address	F8h	Non-data
Set Max Address	F9h	Non-data
Set Max Set Password	F9h	PIO data-out
Set Max Lock	F9h	Non-data
Set Max Freeze Lock	F9h	Non-data
Set Max Unlock	F9h	PIO data-out
48-bit Address Feature Set		
Flush Cache Ext	EAh	Non-data
Read Sector(s) Ext	24h	PIO data-in
Read DMA Ext	25h	DMA
Read Multiple Ext	29h	PIO data-in
Read Native Max Address Ext	27h	Non-data
Read Verify Sector(s) Ext	42h	Non-data
Set Max Address Ext	37h	Non-data
Write DMA Ext	35h	DMA
Write Multiple Ext	39h	PIO data-out
Write Sector(s) Ext	34h	PIO data-out
NCQ Feature Set		
Read FPDMA Queued	60h	DMA Queued
Write FPDMA Queued	61h	DMA Queued
Miscellaneous and Historical Commands		
Data Set Management	06h	DMA
Seek	70h	Non-data

3.2 Identify Device

Word	F/V	Default Value	Description
0	F	0040h	General configuration
1	X	XXXXh	Default number of cylinders
2	V	0000h	Reserved
3	X	00XXh	Default number of heads
4	X	0000h	Obsolete
5	X	0240h	Obsolete
6	F	XXXXh	Default number of sectors per track
7 - 8	V	XXXXh	Number of sectors per card (Word 7 = MSW, Word 8 = LSW)
9	X	0000h	Obsolete
10 - 19	F	XXXXh	Serial number in ASCII (Right justified)
20	X	0002h	Obsolete
21	X	0002h	Obsolete
22	X	0000h	Obsolete
23 - 26	F	XXXXh	Firmware revision in ASCII Big Endian Byte Order in Word
27 - 46	F	XXXXh	Model number in ASCII (Left justified) Big Endian Byte Order in Word
47	F	8001h	Maximum number of sectors on Read/Write Multiple command
48	F	0000h	Reserved
49	F	0300h	Capabilities
50	F	0400h	Capabilities
51	F	0200h	PIO data transfer cycle timing mode
52	X	0000h	Obsolete
53	F	0007h	Field validity
54	X	XXXXh	Current numbers of cylinders
55	X	XXXXh	Current numbers of heads
56	X	XXXXh	Current sectors per track
57 - 58	X	XXXXh	Current capacity in sectors (LBAs) (Word 57 = LSW , Word 58 = MSW)
59	F	0101h	Multiple sector setting
60 - 61	F	XXXXh	Total number of user addressable logical sectors for 28-bit commands (DWord)



Word	F/V	Default Value	Description
62	X	0000h	Reserved
63	F	0207h	Multiword DMA transfer Supports MDMA mode 0, 1 and 2
64	F	0003h	Advanced PIO modes supported
65	F	0078h	Minimum Multiword DMA transfer cycle time per word
66	F	0078h	Recommended Multiword DMA transfer cycle time
67	F	0078h	Minimum PIO transfer cycle time without flow control
68	F	0078h	Minimum PIO transfer cycle time with IORDY flow control
69	F	4000h	Additional supported
70 - 74	F	0000h	Reserved
75	F	001Fh	Queue depth
76	F	030Eh	Serial ATA capabilities <ul style="list-style-type: none"> • Supports Serial ATA Gen3 • Supports Serial ATA Gen2 • Supports Serial ATA Gen1 • Supports Phy event counters log • Supports receipt of host initiated power management requests • Supports Native Command Queuing
77	F	0080h	Serial ATA additional capability <ul style="list-style-type: none"> • DevSleep to Reduced Power State
78	F	0148h	Serial ATA features supported <ul style="list-style-type: none"> • Supports Device Sleep • Supports software settings preservation • Device supports initiating power management
79	V	0040h	Reserved
80	F	03FCh	Major version number (ACS-2)
81	F	0000h	Minor version number
82	F	702Bh	Command sets supported 0
83	F	7500h	Command sets supported 1
84	F	4002h	Command sets supported 2
85 - 87	V	XXXXh	Command set/feature enabled
88	V	007Fh	Ultra DMA mode supported and selected
89	F	0003h	Time required for a Normal Erase mode Security Erase Unit
90	F	0001h	Time required for an Enhanced Erase mode Security Erase Unit
91	V	0000h	Current advanced power management value
92	V	FFFEh	Master password identifier

Word	F/V	Default Value	Description
93 - 99	V	0000h	Reserved
100 - 103	V	XXXXh	Maximum user LBA for 48-bit address feature set
104	V	0000h	Reserved
105	F	0100h	Maximum number of 512-byte blocks per Data Set Management
106 - 127	V	0000h	Reserved
128	V	0009h	Security status
129 - 159	X	XXXXh	Vendor specific
160	F	0000h	Power requirement description
161	X	0000h	Reserved
162	F	0000h	Key management schemes supported
163	F	0000h	CF Advanced True IDE Timing mode capability and setting
164 - 168	V	0000h	Reserved
169	F	0001h	Data Set Management supported
170 - 216	V	XXXXh	Reserved
217	F	0001h	Non-rotating media (SSD)
218 - 221	X	0000h	Reserved
222	F	107Fh	Transport major revision (SATA Rev 3.1)
223 - 254	X	0000h	Reserved
255	X	XXXXh	Integrity word

Notes:

1. F = content (byte) is fixed and does not change.
2. V = content (byte) is variable and may change depending on the state of the device or the commands executed by the device.
3. X = content (byte) is vendor specific and may be fixed or variable.

3.3 Identify Device SMART Feature Set

Value	Command	Value	Command
D0h	Read Data	D5h	Read Log
D1h	Read Attribute Threshold	D6h	Write Log
D2h	Enable/Disable Autosave	D8h	Enable SMART Operations
D3h	Save Attribute Values	D9h	Disable SMART Operations
D4h	Execute OFF-LINE Immediate	DAh	Return Status

If the reserved size is below the threshold, the status can be read from the Cylinder Register using the Return Status command (DAh).

3.4 SMART Data Feature

The following 512 bytes make up the device SMART data structure. Users can obtain the data using the “Read Data” command (D0h).

Byte	F / V	Description
0 - 1	X	Revision code
2 - 361	X	Vendor specific (see 4.3.2)
362	V	Off-line data collection status
363	X	Self-test execution status byte
364 - 365	V	Total time in seconds to complete off-line data collection activity
366	X	Vendor specific
367	F	Off-line data collection capability
368 - 369	F	SMART capability
370	F	Error logging capability <ul style="list-style-type: none"> • 7-1 Reserved • 0 1 = Device error logging supported
371	X	Vendor specific
372	F	Short self-test routine recommended polling time (in minutes)
373	F	Extended self-test routine recommended polling time (in minutes)
374	F	Conveyance self-test routine recommended polling time (in minutes)
375 - 385	R	Reserved
386 - 395	F	Firmware version/date code
396 - 399	F	Reserved
400 - 408	F	‘SM2246XT’
409 - 415	X	Vendor specific
416 - 417	F	Reserved
418 - 419	V	Number of spare block

Byte	F / V	Description
420	F	Reserved
421 - 422	V	Average erase count
423	F	Reserved
424 - 425	V	Max erase count
426	F	Reserved
427 - 428	V	Min erase count
429 - 510	X	Vendor specific
511	V	Data structure checksum

Note:

1. F = content (byte) is fixed and does not change.
2. V = content (byte) is variable and may change depending on the state of the device or the commands executed by the device.
3. X = content (byte) is vendor specific and may be fixed or variable.
4. R = content (byte) is reserved and shall be zero.

3.5 SMART Attributes

The following table defines the vendor specific data in byte 2 to 361 of the 512-byte SMART data.

Attribute ID (hex)	Raw Attribute Value							Attribute Name
01	MSB	00	00	00	00	00	00	Read error rate
05	LSB	MSB	00	00	00	00	00	Reallocated sectors count
09	LSB			MSB	00	00	00	Power-on hours
0C	LSB			MSB	00	00	00	Power cycle count
A0	LSB			MSB	00	00	00	Uncorrectable sector count when read/write
A1	LSB	MSB	00	00	00	00	00	Number of valid spare block
A2	LSB	MSB	00	00	00	00	00	Number of cache data block
A3	LSB	MSB	00	00	00	00	00	Number of initial invalid block
A4	LSB			MSB	00	00	00	Total erase count
A5	LSB			MSB	00	00	00	Maximum erase count
A6	LSB			MSB	00	00	00	Minimum erase count
A7	LSB			MSB	00	00	00	Average erase count
C0	LSB			MSB	00	00	00	Power-off retract count
C2	MSB	00	00	00	00	00	00	Controlled temperature
C3	LSB			MSB	00	00	00	Hardware ECC recovered
C4	LSB			MSB	00	00	00	Reallocation event count
C7	LSB	MSB	00	00	00	00	00	Ultra DMA CRC error count
F1	LSB			MSB	00	00	00	Total LBAs written (each write unit = 32MB)
F2	LSB			MSB	00	00	00	Total LBAs read (each read unit = 32MB)

4. Part No. Decoder

4.1 Part No. Decoder

1	-	2	3	4	5	6	7	8	9
Product Line	-	Form Factor	Product Series	Cervoz Family Code (Bus / Internal Control)	Flash Brand	Flash Capacity	Flash Mode	Module Capacity	Operating Temp.
XXX	-	XX	X	XXX	X	X	X	XXXX	X

1. Product Line

CIS	Cervoz Industrial SSD
CIM	Cervoz Industrial Memory Card
CIE	Cervoz Industrial Embedded Module

2. Form Factor

2S	2.5" SATA
2P	2.5" PATA
CF	CompactFlash
CA	CFast
MS	mSATA
HM	Half Size mSATA
HS	Half Slim
M4	M.2 2242
M6	M.2 2260
M8	M.2 2280
0V	PATA Disk 40pin Vertical
4V	PATA Disk 44pin Vertical
4L	PATA Disk 44pin Horizontal Left
7T	SATA Disk 7pin Vertical Tall
7L	SATA Disk 7pin Horizontal Left
7R	SATA Disk 7pin Horizontal Right

3. Product Series

S	Supreme Series (SLC)
R	Reliance Series (RO-MLC)
M	Momentum Series (MLC)

4. Cervoz Family Code

Bus and Internal Control for Cervoz Product Families

5. Flash Brand

M	Micron
T	Toshiba

6. Flash Capacity

A	256Mb
B	512Mb
C	1Gb
D	2Gb

E	4Gb
F	8Gb
G	16Gb
H	32Gb
I	64Gb
J	128Gb
K	256Gb
L	512Gb
M	1Tb

7. Flash Mode

Internal Control for Flash Mode

8. Module Capacity

128M	128MB
256M	256MB
512M	512MB
001G	1GB
002G	2GB
004G	4GB
008G	8GB
016G	16GB
032G	32GB
064G	64GB
128G	128GB
256G	256GB
512G	512GB

9. Operating Temperature

S	Standard Grade (0~ +70°C)
W	Wide Temperature Grade (-40 ~ +85°C)