



Features

- 10.1" New Generation Stainless Steel Display
- True Flat Front Bezel Design and Grade 304 Stainless Steel Enclosure (Grade 316 for Option)
- IP66/IP69K Rated with M12 Connectors
- Support Resistive Touch, Projected Capacitive Touch, and Glass
- Touch on/off Button on the Side Edge for Hygienic Cleaning
- Support Ergonomic Versatile Mounting: Yoke Mounting / Space-saving VESA 75 mm Mounting

Specifications

I/O port – Standard m12 I/O Connector on the Rear Side

VGA	1 x M12 VGA by 12-pin cable with waterproof cap
HDMI	1 x waterproof HDMI with waterproof cap
Touch	1 x M12 for USB touch with waterproof cap
Power	1 x Power input 1 x Touch on/off button on the side
OSD Control Membrane	OSD on the rear side
Speaker	1 x 2W IP65 speaker (optional)

Display	Standard	High Brightness optional
Display Type	10.1" color TFT LCD	10.1" color TFT LCD
Max. Resolution	1280 x 800	1280 x 800
Max. Color	16.7M	16.7M
Luminance (cd/m ²)	350	1000
View Angle	170(H) / 170(V)	170(H) / 170(V)
Contrast	800: 1	800:1
Backlight Lifetime	15,000 Hrs	30,000 Hrs
Option	Optical Boading	Optical Boading

Touch Screen	Resistive Touch	PCT	Glass
TS Control IC	PenMount 6000 on Board	Chip on tail	NA
Interface	USB interface	USB interface	AR
Light Transmission	Over 80%	Over 90%	Over 90%

Power

Power input	9~36V DC
Power Consumption	MAX: 6.2W (110R) / MAX: 11W (110P)

Mechanical

Color	304 Stainless Steel Enclosure (Default) 316 Stainless Steel Enclosure (Optional)
Construction	Stainless steel enclosure
Mounting	VESA mount 75 x 75, Yoke mount
IP Rating	IP66/IP69K
Dimension	300 x 220 x 53 mm
Net Weight	3.5 Kg

Dimensions

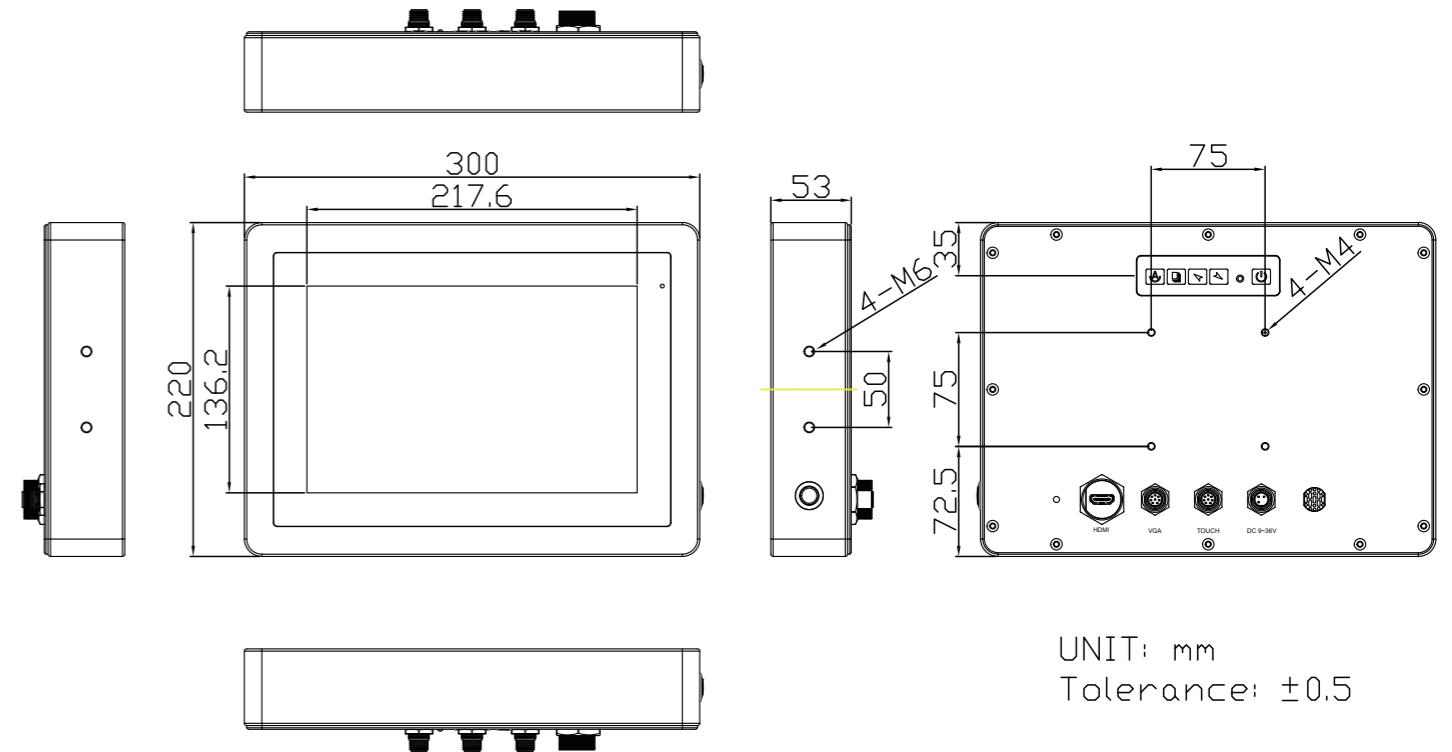

Environmental

Operating temperature(°C)	-20~60°C
Storage temperature(°C)	-30°C~70°C
Storage humidity	10 to 90% @ 40°C, non-condensing
Certification	CE/FCC class A

Ordering information

ViTAM-110P-01	10.1"/1280x800/S.S./PCT(USB)/9~36V/w ADP
ViTAM-110R-01	10.1"/1280x800/S.S./RT(USB)/9~36V/w ADP
ViTAM-110G-01	10.1"/1280x800/S.S./GLASS/9~36V/w ADP
ViTAM-110PH-01	10.1"/1280x800/1000NITS/S.S./PCT(USB)/9~36V/w ADP
ViTAM-110RH-01	10.1"/1280x800/1000NITS/S.S./RT(USB)/9~36V/w ADP
ViTAM-110GH-01	10.1"/1280x800/1000NITS/S.S./GLASS/9~36V/w ADP