



Features

- 15" New Generation Stainless Steel Panel PC
- 6th Gen Intel Core i3-6100U / Core i5-6300U(Optional)
- True Flat Front Bezel Design and Grade 304 Stainless Steel Enclosure (Grade 316 for Option)
- IP66/IP69K Rated with M12 Connectors
- Support Resistive Touch, Projected Capacitive Touch, and Glass
- Touch on/off Button on the Side Edge for Hygienic Cleaning
- Support Ergonomic Versatile Mounting: Yoke Mounting / Space-saving VESA 75 mm Mounting



Specifications

System	
Processor	6th Gen Intel Core i3-6100U / Core i5-6300U(Optional)
System Chipset	SoC
System Memory	1 x SO-DIMM DDR4 slot, up to 16GB
RFID Module	RFID module design on the front side (optional)

Outside I/O Port-Standard M12 I/O Connector on the rear	
USB	1 x M12 8-pin for USB 2.0 with waterproof cap
Serial/Parallel	1 x M12 8pin for COM 1, RS-232/422/485, Default RS-232, with waterproof cap
LAN	1 x M12 8pin for LAN with waterproof cap
Power	1 x M12 3pin DC Power with waterproof cap 1 x Power Switch on the rear side
Others	1 x Touch on/off button on the side
Option	2 x optional blank M12 connectors with waterproof cap for selecting two from the following options: 2 x USB 2.0 1 x USB 3.0 1 x LAN Port 1 x COM Port 1 x CAN Bus 1 x POE

Storage Space	
HDD	1 x 2.5" HDD/SSD Space 1 x mSATA slot onboard

Expansion	
Expansion Slot	1 x Mini PCIe slot for WIFI/BT (optional)

Display	Standard	High Brightness optional
Display Type	15" TFT LCD	15" TFT LCD
Max. Resolution	1024 x 768	1024 x 768
Max. Color	262k	262k/16.2M
Luminance (cd/m ²)	420	1000
View Angle	160(H) / 160(V)	160(H) / 150(V)
Contrast	800:1	800:1
Backlight Lifetime	50,000 hrs	30,000 Hrs
Option	Optical Bonding	Optical Bonding

Touch Screen	Resistive Touch	PCT	Glass
TS Control IC	PenMount 6000 on Board	Chip on tail	NA
Interface	USB interface	USB interface	AR/AG(option)
Light Transmission	Over 80%	Over 90%	Over 90%

Dimensions

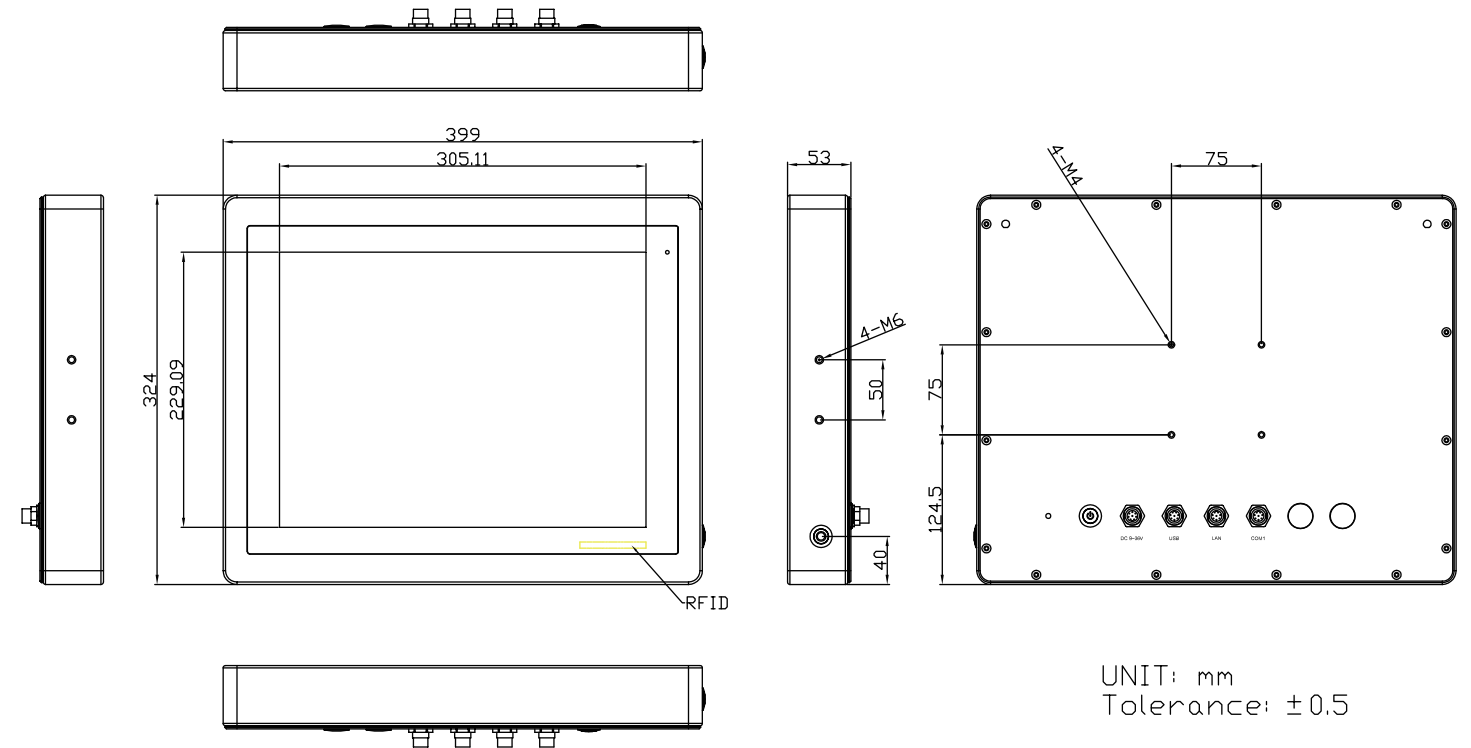

Power	
Power input	DC 9~36V
Power Consumption	TBD

Mechanical	
Color	304 Stainless Steel Enclosure (Default) 316 Stainless Steel Enclosure (Optional)
Construction	Stainless steel enclosure
Mounting	VESA mount 75 x 75, Yoke mount
IP Rating	Total IP66 / IP69K
Dimension	399 x 324 x 53
Net Weight	7.1 Kg

Environmental	
Operating temperature(°C)	-20~60°C
Storage temperature(°C)	-30°C~70°C
Storage humidity	10 to 90% @ 40°C, non-condensing
Certification	CE/FCC class A

Operating System Support	
Windows 7 64 bit / Windows 8 64 bit / Windows 10 IoT 64 bit	

Ordering information	
VITAM-915AP-01	15"/1024x768/S.S./I3-6100U/32GMLC SSD/PCT/9~36V/w ADP
VITAM-915AR-01	15"/1024x768/S.S./I3-6100U/32GMLC SSD/RT/9~36V/w ADP
VITAM-915AG-01	15"/1024x768/S.S./I3-6100U/32GMLC SSD/GLASS/9~36V/w ADP
VITAM-915APH-01	15"/1024x768/1000NITS/S.S./I3-6100U/32GMLC SSD/PCT/9~36V/w ADP
VITAM-915ARH-01	15"/1024x768/1000NITS/S.S./I3-6100U/32GMLC SSD/RT/9~36V/w ADP
VITAM-915AGH-01	15"/1024x768/1000NITS/S.S./I3-6100U/32GMLC SSD/GLASS/9~36V/w ADP