



Features

- 17" New Generation Stainless Steel Panel PC
- 4th Generation Intel Core i3-4010U/i5-4350U Onboard Processor
- True Flat Front Bezel Design and Grade 304 Stainless Steel Enclosure (Grade 316 for Option)
- IP66/IP69K Rated with M12 Connectors
- Support Resistive Touch, Projected Capacitive Touch, and Glass
- Touch on/off Button on the Side Edge for Hygienic Cleaning
- Support Ergonomic Versatile Mounting: Yoke Mounting / Space-saving VESA 100 mm Mounting



Specifications

System	
Processor	Onboard 4th Gen. Intel Core i3-4010U/i5-4350U
System Chipset	SoC
System Memory	Onboard 4GB DDR 3L 1600 MHz/8GB (optional)
RFID Module	RFID module design on the front side (optional)

Outside I/O Port-Standard M12 I/O Connector on the rear	
USB	1 x M12 8-pin for USB 2.0 with waterproof cap
Serial/Parallel	1 x M12 8pin for COM 1, RS-232/422/485, Default RS-232, with waterproof cap
LAN	1 x M12 8pin for LAN with waterproof cap
Power	1 x M12 3pin DC Power with waterproof cap 1 x Power Switch on the rear side
Others	1 x Touch on/off button on the side
Option	2 x optional blank M12 connectors with waterproof cap for selecting two from the following options: 2 x USB 2.0 1 x USB 3.0 1 x LAN 1 x COM Port 1 x CAN

Storage Space	
HDD	1 x 2.5" HDD / SSD

Expansion	
Expansion Slot	1 x Mini PCIe slot for WIFI/BT (optional)

Display	Standard	High Brightness optional
Display Type	17" color TFT LCD	17" color TFT LCD
Max. Resolution	1280 x 1024	1280 x 1024
Max. Color	16.7M	16.7M
Luminance (cd/m ²)	350	1000
View Angle	170(H) / 170(V)	170(H) / 160(V)
Contrast	1000:1	1000:1
Backlight Lifetime	50,000 Hrs	50,000 Hrs
Option	Optical Bonding	Optical Bonding

Touch Screen	Resistive Touch	PCT	Glass
TS Control IC	PenMount 6000 on Board	Chip on tail	NA
Interface	USB interface	USB interface	AR
Light Transmission	Over 80%	Over 90%	Over 90%

Dimensions

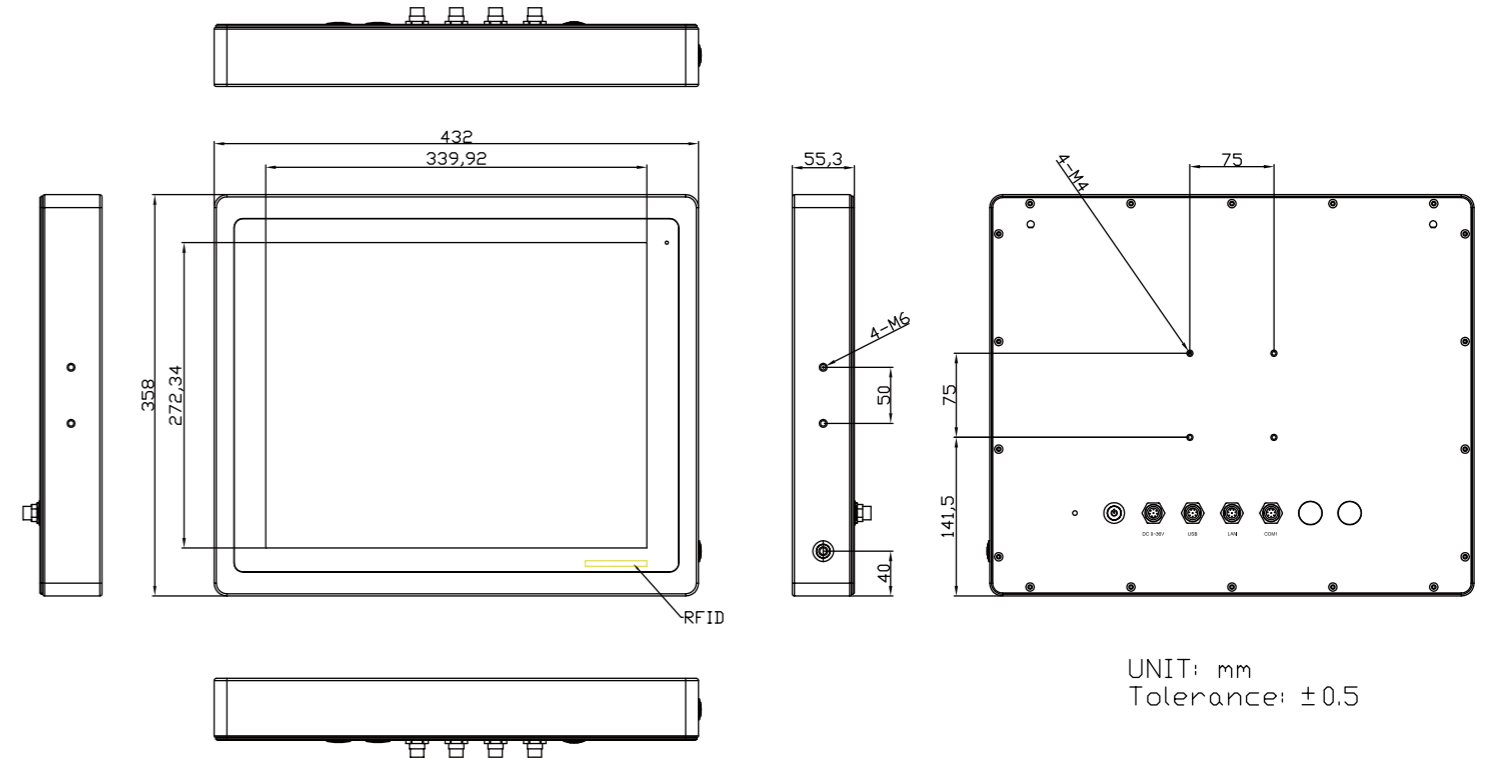

UNIT: mm
Tolerance: ±0.5

Power	
Power input	9~36V DC
Power Consumption	MAX:41.2W(917R) / MAX:38.5W(917P)

Mechanical	
Color	304 Stainless Steel Enclosure (Default) 316 Stainless Steel Enclosure (Optional)
Construction	Stainless steel enclosure
Mounting	VESA mount 75 x 75, Yoke mount
IP Rating	IP66/IP69K
Dimension	432 x 358 x 55.3 mm
Net Weight	8 Kg

Environmental	
Operating temperature(°C)	-20~60°C
Storage temperature(°C)	-30°C~70°C
Storage humidity	10 to 90% @ 40°C, non-condensing
Certification	CE/FCC class A

Operating System Support	
Windows 7 Embedded Enterprise, Windows Embedded Standard 7, Windows Embedded 8.1 Pro, Windows Embedded 8.1 Industry Pro, Windows 10 IoT 2016	

Ordering information	
VITAM-917P-01	17"/1280x1024/S.S./I3-4010U/4G/32GMLC SSD/PCT/9~36V/w ADP
VITAM-917R-01	17"/1280x1024/S.S./I3-4010U/4G/32GMLC SSD/RT/9~36V/w ADP
VITAM-917G-01	17"/1280x1024/S.S./I3-4010U/4G/32GMLC SSD/GLASS/9~36V/w ADP
VITAM-917PH-01	17"/1280x1024/1000NITS/S.S./I3-4010U/4G/32GMLC SSD/PCT/9~36V/w ADP
VITAM-917RH-01	17"/1280x1024/1000NITS/S.S./I3-4010U/4G/32GMLC SSD/RT/9~36V/w ADP
VITAM-917GH-01	17"/1280x1024/1000NITS/S.S./I3-4010U/4G/32GMLC SSD/GLASS/9~36V/w ADP